



# Microtips Technology Inc.

台北縣汐止鎮康寧街169巷31號12樓  
12F, No 31, Lane 169, Kang Ning St.  
Hsi-Chih, Taipei Hsien, Taiwan, R.O.C.

WEB : <http://www.microtips.com.tw>  
E-mail : [Macros@microtips.com.tw](mailto:Macros@microtips.com.tw)  
TEL: 886-2-2695-3133 FAX :886-2-2695-8625

## LCD MODULE SPECIFICATION FOR CUSTOMER'S APPROVAL

CUSTOMER : Standard

MODULE TYPE : MTG-F24128DFWHSAY-A

APPROVED BY: (FOR CUSTOMER USE ONLY)

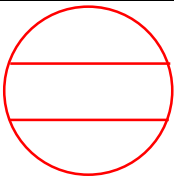
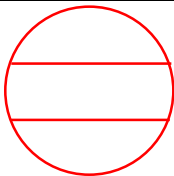
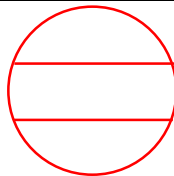
Approved By	Checked By	Prepared By	MT File No	Date Issued
			MTG-24128D	2/22/2002

# CONTENTS

<b>ITEM</b>	<b>Page</b>
FEATURES	3
LCD MODULE DRAWING	4
GENERAL SPECIFICATION	5
ABSOLUTE MAXIMUM RATING	5
ELECTRICAL CHARACTERISTICS	6
OPTICAL CHARACTERISTICS	6
MECHANICAL SPECIFICATION	7
INTERFACE PIN ASSIGNMENT	8
BLOCK DIAGRAM	11
POWER SUPPLY	11
AC CHARACTERISTICS	12
TIMING CHART	12
COMMAND LIST	13
CG-ROM CHARACTER CODE MAP	27
DSIPLAY PATTERN	27
RELIABILITY TEST	28
APPEARANCE CHECK	28
HANDLING PRECAUTIONS	29
LCD PRODUCT QUALITY STANDARD	30
RIVISION HISTORY	31

**SPECIFICATION FOR**  
**LIQUID CRYSTAL DISPLAY MODULE**  
**MODEL NO. : MTG-F24128DFWHSAY-A**

View Direction	<input checked="" type="checkbox"/> 6 O'clock		<input type="checkbox"/> 12 O'clock		
LCD Type	<input checked="" type="checkbox"/> FSTN Positive		<input type="checkbox"/> FSTN Negative		
	<input type="checkbox"/> STN Gray	<input type="checkbox"/> STN Yellow Green	<input type="checkbox"/> STN Blue		
Rear Polarizer	<input type="checkbox"/> Reflective	<input checked="" type="checkbox"/> Transflective		<input type="checkbox"/> Transmissive	
Backlight Type	<input checked="" type="checkbox"/> LED	<input type="checkbox"/> Internal Power	<input type="checkbox"/> EL	<input type="checkbox"/> 5V input	
		<input type="checkbox"/> External Power	<input type="checkbox"/> CCFL	<input checked="" type="checkbox"/> 10.5V input	
Backlight Color	<input type="checkbox"/> White	<input type="checkbox"/> Amber	<input type="checkbox"/> Blue Green	<input checked="" type="checkbox"/> Yellow Green	<input type="checkbox"/> Other
Temperature Range	<input type="checkbox"/> Normal		<input checked="" type="checkbox"/> Wide		<input type="checkbox"/> Super Wide
EL Driver IC	<input type="checkbox"/> Build-in		<input checked="" type="checkbox"/> Not Build-in		
Touch Screen	<input type="checkbox"/> With		<input checked="" type="checkbox"/> Without		

**TO BE VERY CAREFUL !**

The LCD driver ICs are made of CMOS process, which is very easy to be damaged by static charge, make sure the user is grounded when handling the LCM.



## GENERAL SPECIFICATION

Item	Content
Display Resolution	240(H)×128(W)
Dimensional Outline(mm)	144.0 (W)×104.0 (W)×14.1(D) max
Display mode	Transflective Type
Circuit	Controller IC, Common-Driver IC, Segment-driver IC
Interface	Data (DB0~DB7), C/D, WR, RD, CE, RES, MD2, FS, V <sub>EE</sub> .

## ABSOLUTE MAXIMUM RATING

### (1) Electrical Absolute Ratings

Item	Symbol	Min.	Max.	Unit	Note
Power Supply for Logic	V <sub>DD</sub> -V <sub>SS</sub>	-0.3	5.5	Volt	
Power Supply for LCD	V <sub>EE</sub> -V <sub>SS</sub>	-26.0	0	Volt	
Input Voltage	V <sub>I</sub>	-0.3	V <sub>DD</sub>	Volt	
Supply Current for LED backlight	I <sub>LED</sub>		880	mA	

### (2) Environmental Absolute Maximum Ratings

Item	Normal Temperature				Wide Temperature			
	Operating		Storage		Operating		Storage	
	Max,	Min.	Max,	Min.	Max,	Min.	Max,	Min.
Ambient Temperature	0°C	+50°C	-20°C	+70°C	-20°C	+70°C	-30°C	+80°C
Humidity(without condensation)	Note 2,4		Note 3,5		Note 4,5		Note 4,6	

Note 2 Ta ≤ 50°C : 80% RH max

Ta > 50°C : Absolute humidity must be lower than the humidity of 85%RH at 50°C

Note 3 Ta at -20°C will be <48hrs at 70°C will be <120hrs when humidity is higher than 75%.

Note 4 Background color changes slightly depending on ambient temperature. This phenomenon is reversible.

Note 5 Ta ≤ 70°C : 75RH max

Ta > 70°C : absolute humidity must be lower than the humidity of 75%RH at 70°C

Note 6 Ta at -30°C will be <48hrs, at 80 °C will be <120hrs when humidity is higher than 75%.

## ELECTRICAL CHARACTERISTICS

Item	Symbol	Condition	Min.	Typ	Max.	Unit	note
Power Supply for Logic	$V_{DD}-V_{SS}$	-	4.5	5.0	5.5	Volt	
Input Voltage	$V_{IL}$	L level	$V_{SS}$	$0.2 V_{DD}$	-	Volt	
	$V_{IH}$	H level	$0.8 V_{DD}$	$V_{DD}$	-	Volt	
LCM Recommend LCD Module Driving Voltage	$V_{DD}-V_O$ Bias=1/12	$T_a=-20^{\circ}C$	-	-	-	Volt	
		$T_a=25^{\circ}C$	15.8	16.3	16.8		
		$T_a=70^{\circ}C$	-	-	-		
Power Supply Current for LCM	$I_{DD}$	$V_{DD}=5.0V$ $V_{DD}-V_O=16.3V$ FLM=64Hz $V_{LED}=10.5V$	-	15	22	mA	
	$I_{EE}$		-	3.0	3.5		
	$I_{LED}^*$		-	440	660		

## OPTICAL CHARACTERISTICS

Item	Symbol	Condition	Min.	Typ	Max.	Unit	note
Viewing angle range	$\Phi f(12\text{ o'clock})$	When $Cr \geq 2$	-	41	-	Degree	9,10
	$\Phi b(6\text{ o'clock})$		-	34	-		
	$\Phi l(9\text{ o'clock})$		-	35	-		
	$\Phi r(3\text{ o'clock})$		-	30	-		
Rise Time	$T_r$	$V_{DD}-V_O=16.3V$ $T_a=25^{\circ}C$		140		mS	
Fall Time	$T_f$			240			
Frame frequency	F <sub>rm</sub>		-	64	-	Hz	8,10
Contrast	Cr		-	5	-		7

## MECHANICAL SPECIFICATION

ITEM	DESCRIPTION	
Product No.		MTG-S24128DFWHSAY-A
Module Size		144.0 (W)mm×104.0(H)mm×14.1(D)mm Max
Dot Size		0.43(W)mm×0.43(H)mm
Dot Pitch		0.45(W)mm×0.45(H)mm
Resolution		240(W)×128(H) Dots Matrix
Duty Ratio		1/128 Duty
LCD Display Mode	STN	<input type="checkbox"/> Gray Mode <input type="checkbox"/> Yellow Mode <input type="checkbox"/> Blue Mode
	FSTN	<input checked="" type="checkbox"/> Black & White(Normally White/Positive Image) <input type="checkbox"/> Black & White(Normally White/Negative Image)
	Rear Polarizer:	<input type="checkbox"/> Reflective <input checked="" type="checkbox"/> Transflective <input type="checkbox"/> Transmissive <input type="checkbox"/> Transflective(High Transmissive)
Viewing Direction		<input checked="" type="checkbox"/> 6 O'clock <input type="checkbox"/> 12 O'clock <input type="checkbox"/> 3 O'clock <input type="checkbox"/> 9 O'clock
Backlight		<input type="checkbox"/> W/O <input type="checkbox"/> CCFL <input type="checkbox"/> EL <input checked="" type="checkbox"/> LED
Controller		Toshiba T6963C
DC/DC for EL		Without (Optional)
EL Driver		Without (Optional)

## INTERFACE PIN ASSIGNMENT

PIN NO.	PIN OUT	FUNCTION DESCRIPTION
1	V <sub>SS</sub>	GND
2	V <sub>DD</sub>	Logic supply voltage
3	V <sub>o</sub>	Bias Voltage for LCD panel
4	C/D	Command/Data Register select
5	RD	Read Data
6	WR	Write Data
7	DB0	Data Bus
14	DB7	
15	CE	Chip Enable
16	RES	Reset
17	V <sub>EE</sub>	LCD driver supply voltage
18	MD2	H=32, L=40
19	FS	Font Select. H=6x8 dot matrix, L=8x8 Dot matrix
20	NC/LED A	No Connection for Reflective type or with EL backlight. Anode of LED Backlight. See the JUMPER EXPLANATION below:

### JUMPER EXPLANATION

1. If JP2 is short, The Cathode of LED backlight is short with V<sub>SS</sub>, user could supply 10.3~10.5V to pin20 for LED backlight ON/OFF.
  2. If JP2 open, the backlight is fully independent with the logic, control the backlight via A/K (A/K are the terminals of the LED backlight).
  3. Keep JP1 open. It is the jumper of V<sub>DD</sub> and the Anode for LED backlight.
  4. JP4 to JP8 are for the internal M-clock adjustment, they are optimal and don't change them
  5. Never change the polarity of J1 and J2, it may burn off your system.
  6. J3 short: Bezel and screw holes connected to V<sub>SS</sub>. J1 open: Bezel and screw holes floating
- Note: J3, JP1 and JP2 are #0805 0 ohm resistors on the rear side of the PCB.

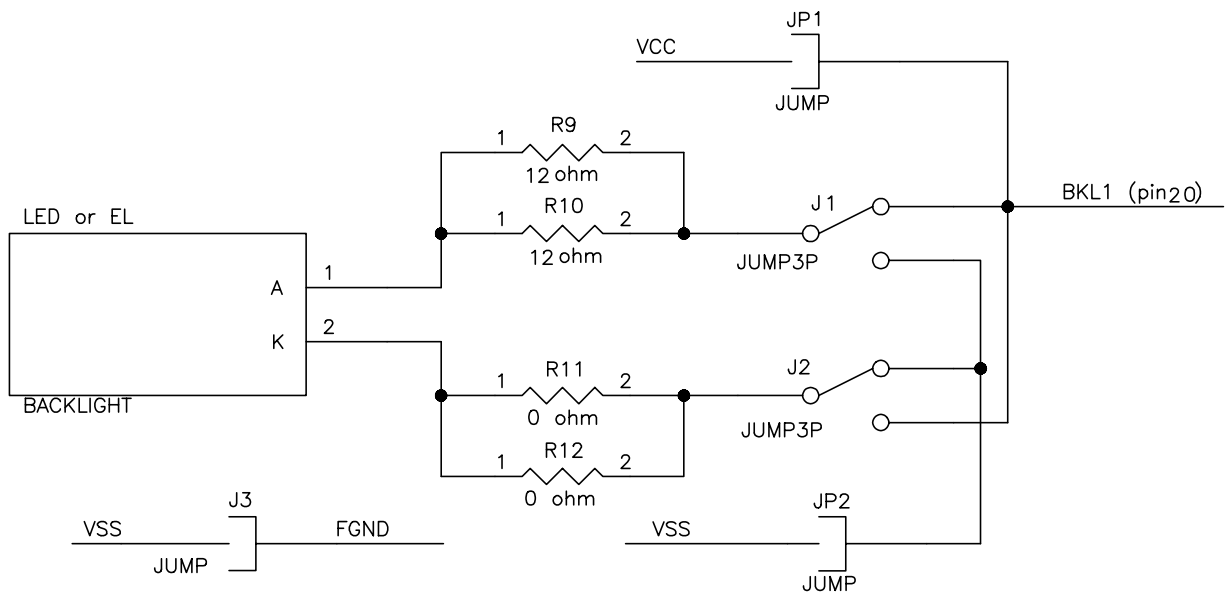

**[Note 7] Definition of Operation Voltage (Vop)**

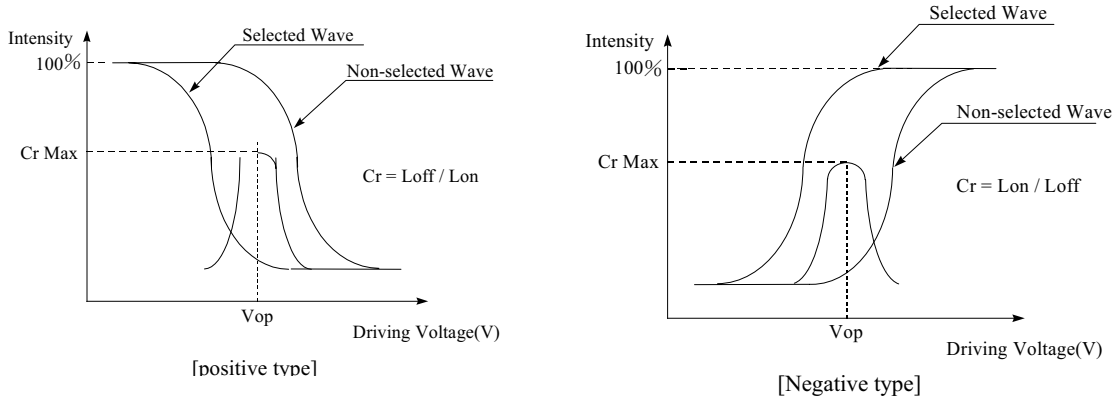

**[Note 8] Definition of Response Time (Tr, Tf)**

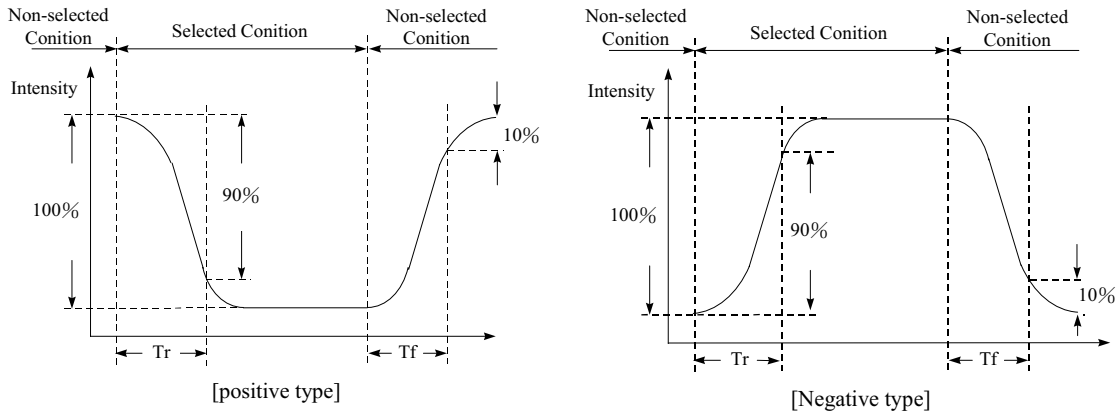

**Conditions:**

**Operating Voltage : Vop**  
**Frame Frequency : 64 Hz**

**Viewing Angle( $\theta, \varphi$ ):  $0^\circ, 0^\circ$**   
**Driving Wave form : 1/N duty, 1/a bias**

**[Note 9] Definition of Viewing Direction**

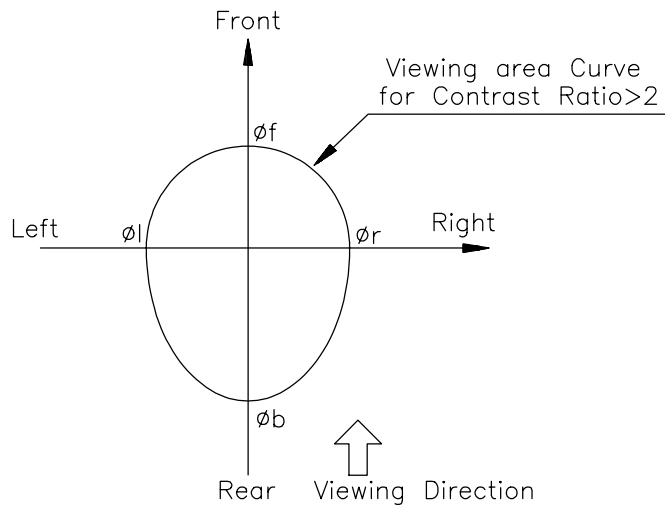

**[Note 10] Definition of viewing angle**

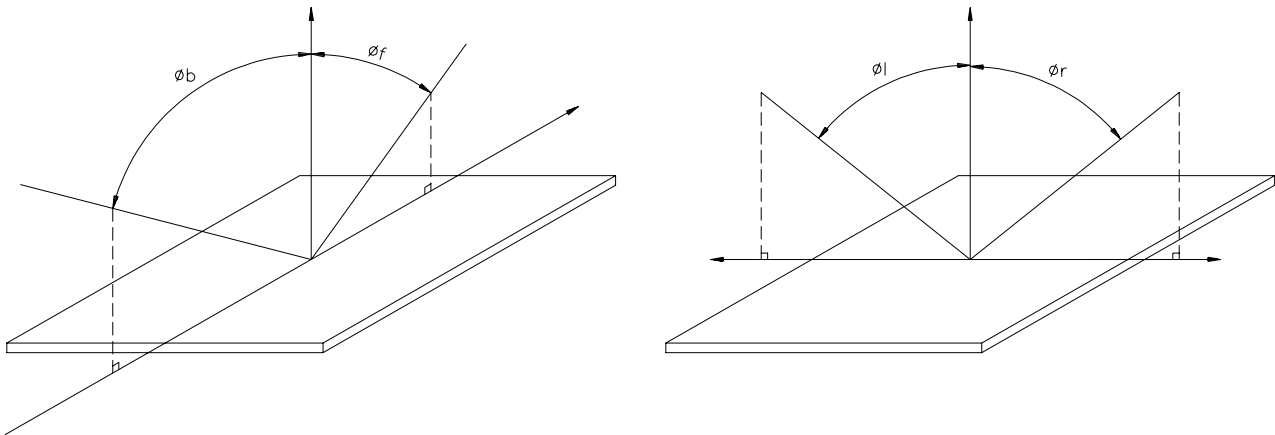

**[Note 11] Description of Measuring Equipment**

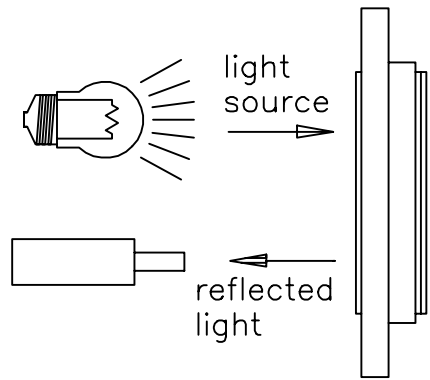

Reflective type

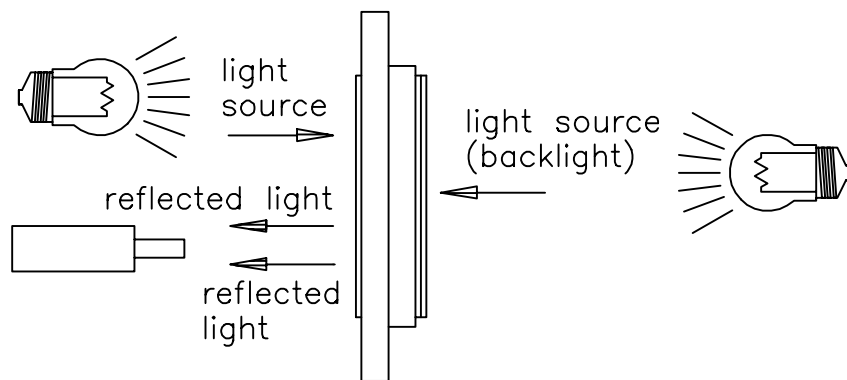

Transflective type

## BLOCK DIAGRAM

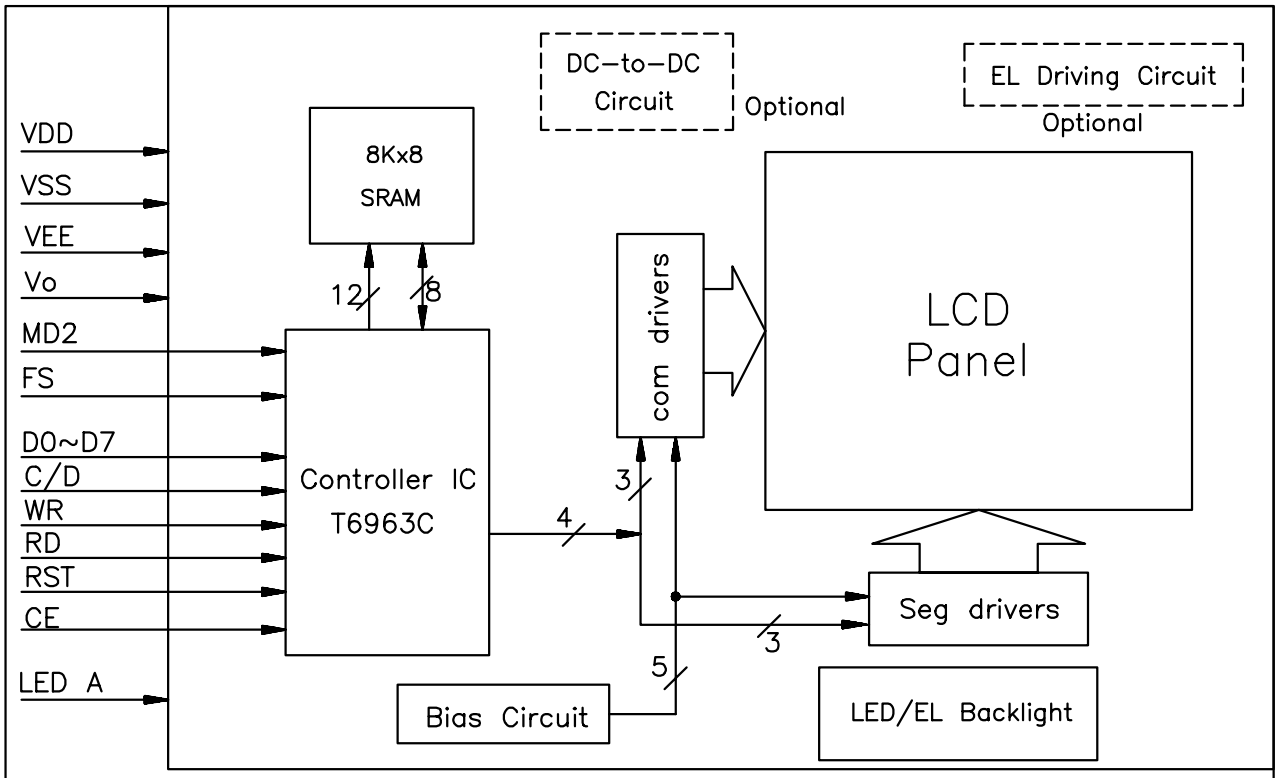

## POWER SUPPLY

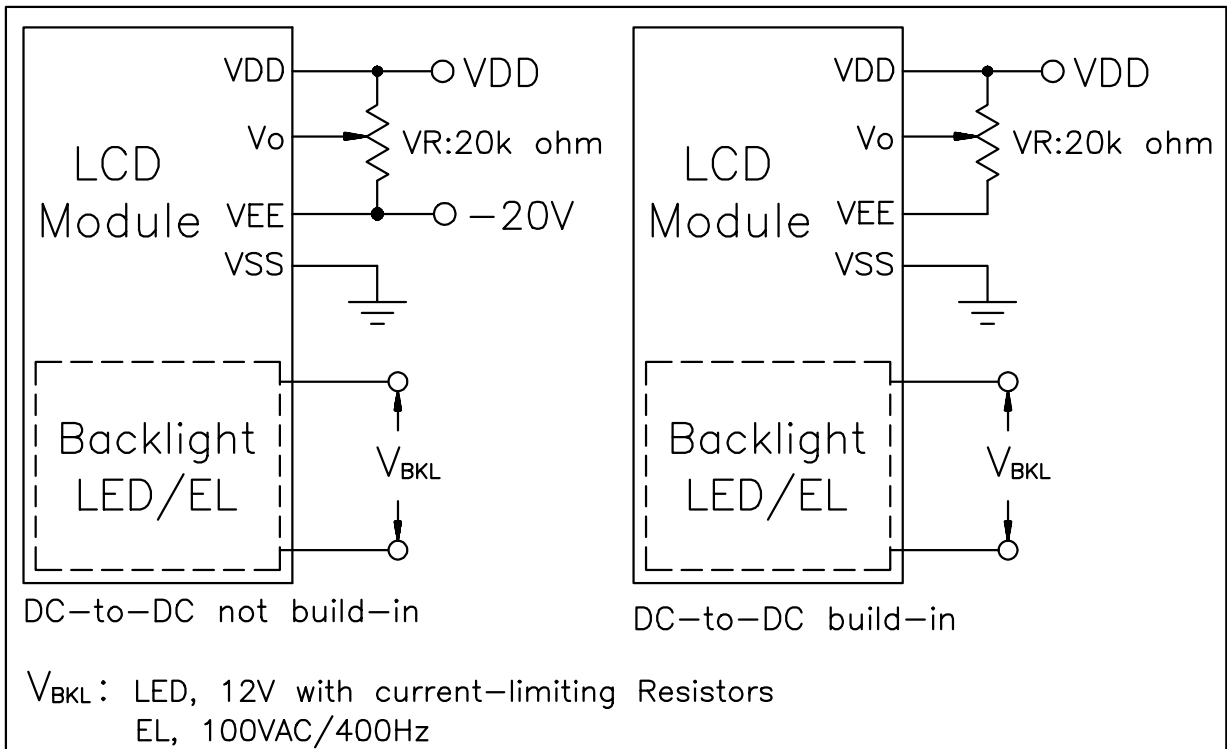

# AC CHARACTERISTIC

( $V_{DD}=5.0V\pm 10\%$ ,  $V_{SS}=0V$ ,  $T_a=0$  to  $50^\circ C$ )

Item	Symbol	Test Condition	Min.	Max.	Unit
C/D setup time	$t_{CDS}$	—	100	—	nS
C/D Hold time	$t_{CDH}$	—	10	—	
CE, RD, WR pulse width	$t_{CDS}$ , $t_{CDS}$ , $t_{CDS}$ ,	—	80	—	
Data setup time	$t_{DS}$	—	80	—	
Data hold time	$t_{DH}$	—	40	—	
Access time	$t_{ACC}$	—	—	150	
Output hold time	$t_{OH}$	—	10	50	

## Timing Chart

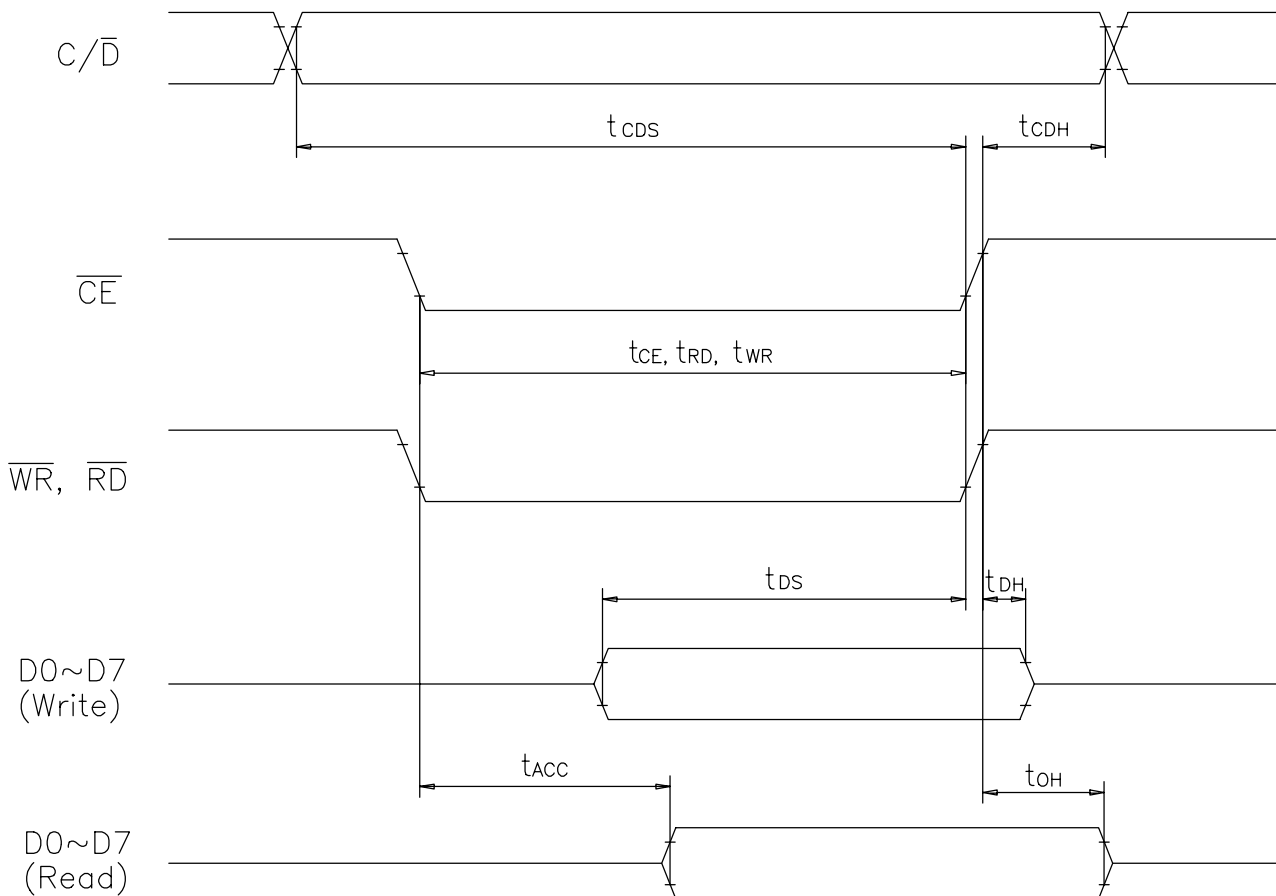

## Command List

Command	Code	D1	D2	Function
Register Set	00100001	X address Data Low Address	X address 00H High Address	Cursor pointer set Offset register set Address pointer set
Control Word Set	01000000 01000001 01000010 01000011	Low address Columns Low address Columns	High address 00H high address 00H	Text home address set Text area set Graphic home address set Graphic area set
Mode Set	1000x000 1000x001 1000x011 1000x100 10000xxx 100111xx	—	—	'OR' mode 'EXOR' mode 'AND' mode 'Text attribute' mode Internal CG ROM mode External CG ROM mode
Display Mode	10010000 1001xx10 1001xx11 100101xx 100110xx 100111xx	—	—	Display off Cursor on, blink off Cursor on, blink on Text on, graphic off Text off, graphic on Text on, graphic on
Cursor Pattern Select	10100000 1010000 10100010 10100011 10100100 10100101 10100110 10100111	—	—	1 line cursor 2 lines cursor 3 lines cursor 4 lines cursor 5 lines cursor 6 lines cursor 7 lines cursor 8 lines cursor
Data Auto Read/Write	10110000 10110001 10110010	—	—	Data auto write set Data auto read set Auto read
Data Read/Write	11000000 11000001 11000010 11000011 11000100 11000101	Data - Data - Data -		Data write and ADP increment Data read and ADP increment Data write and ADP decrement Data read and ADP decrement Data write and ADP nonvariable Data read and ADP nonvariable
Screen Peak	11100000	—	—	Screen peak
Screen Copy	11101000	—	—	Screen copy
Bit Set/Reset	11110xxx 11111xxx 1111x000 1111x001 1111x010 1111x011 1111x100 1111x101 1111x110 1111x111	—	—	Bit reset Bit set Bit0(LSB) Bit1 Bit2 Bit3 Bit4 Bit5 Bit6 Bit7(MSB)

'x' means 'Don't care'

## Setting Registers

Code	HEX.	Function	D1	D2
00100001	21H	Set cursor point	X ADRS	Y ADRS
00100010	22H	Set offset register	Data	00H
00100100	24H	Set address pointer	LOW ADRS	HIGH ADRS

### (1) Set Cursor Pointer

The position of the cursor is specified by X ADRS and Y ADRS. The cursor position can only moved by this command. Data read/write from MPU never change the cursor pointer. X ADRS and Y ADRS are specified as follows:

X ADRS            00H to 4FH(lower 7 bits are valid)  
 Y ADRS            00H to 1FH(lower 5 bits are valid)

#### a) Single-scan

X ADRS 00 to 4FH

Y ADRS 00H to 0FH

#### b) Dual-scan

X ADRS 00 to 4FH

Y ADRS 00H to 0FH  
Upper Screen

Y ADRS 00H to 0FH  
Lower Screen

### (2) Set offset register

The offset register is used to determine the external character generator RAM area. The T6963C has a 16-bit address bus as follows:

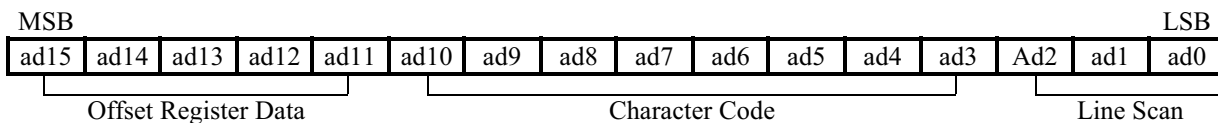

T6963C assign external character generator, when character code set 80H to FFH in using internal character generator. Character codes 00H to 80H assign External character generator, when external generator mode.

The senior 5 bits define the start address in external memory of CG RAM area. The next 8 bits represent the character code of character. In internal CG ROM mode, character codes 00H to 7FH represent the predefined "internal" CG ROM characters, and codes 80H to FFH represent the user's own "external" characters. The 3 least significant bits indicate one of the 8 rows of 8 dots that define the character's shape.

The relationship between display RAM address and offset register

Offset register data	CG RAM hex. Address (start to end)
00000	0000H to 07FFH
00001	0800H to 0FFFH
00010	1000H to 17FFH
11100	E000H to E7FFH
11101	E800H to EFFFH
11110	F000H to F7FFH
11111	F800H to FFFFH

(Example 1)

Offset register	02H				
Character code	80H				
Character generator RAM start address	0001	0100	0000	0000	
	1	4	0	0	H

	Address	Data
	1400H	00H
	1401H	1FH
	1402H	04H
	1403H	04H
	1404H	04H
	1405H	04H
	1406H	04H
	1407H	00H

Text

(Example 2)

The relationship between display RAM data and display characters

<table border="1" style="width: 100%; border-collapse: collapse;"> <tr> <td style="width: 12.5%;">A</td> <td style="width: 12.5%;">B</td> <td style="width: 12.5%;">γ</td> <td style="width: 12.5%;">D</td> <td style="width: 12.5%;">E</td> <td style="width: 12.5%;">ζ</td> <td style="width: 12.5%;">G</td> <td style="width: 12.5%;">H</td> <td style="width: 12.5%;">I</td> <td style="width: 12.5%;">J</td> <td style="width: 12.5%;">K</td> <td style="width: 12.5%;">L</td> <td style="width: 12.5%;">M</td> </tr> <tr> <td style="text-align: center;">①</td> <td style="text-align: center;"> </td> <td style="text-align: center;"> </td> <td style="text-align: center;"> </td> <td style="text-align: center;"> </td> <td style="text-align: center;"> </td> <td style="text-align: center;"> </td> <td style="text-align: center;"> </td> <td style="text-align: center;"> </td> <td style="text-align: center;"> </td> <td style="text-align: center;"> </td> <td style="text-align: center;"> </td> <td style="text-align: center;"> </td> </tr> </table>	A	B	γ	D	E	ζ	G	H	I	J	K	L	M	①													(RAM Data)	(Character)
A	B	γ	D	E	ζ	G	H	I	J	K	L	M																
①																												
	21H	A																										
	22H	B																										
	83H	γ																										
	24H	D																										
	25H	E																										
	86H	ζ																										

γ and ζ are displayed by Character Generator RAM.

(3) Set Address Pointer

The Set Address Pointer command is used to indicate the start address for writing to (or reading from) external RAM.

The Flowchart for Set Address Pointer command:

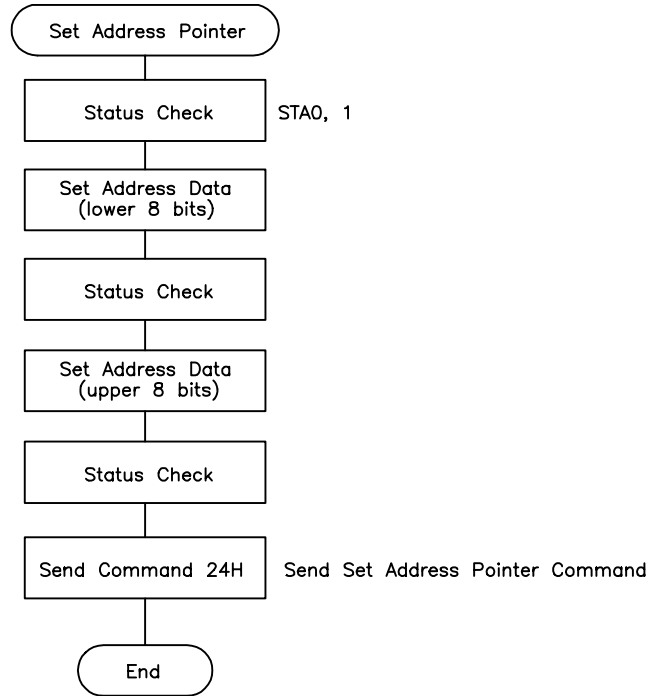

Set Control Word

Code	HEX.	Function	D1	D2
01000000	40H	Set Text Home Address	Lower Address	High Address
01000001	41H	Set Text Area	Columns	00H
01000010	42H	Set Graphic Home Address	Lower Address	High Address
01000011	43H	Set Graphic Area	Columns	00H

The home address and column size are defined by this command.

(1) Set Text Home Address

The starting address in the external display RAM for text display is defined by this command. The text home address indicates the leftmost and uppermost position.

The relationship between external display RAM address and display position

TH		TH+CL
TH+TA		TH+TA+CL
(TH+TA)+TA		(TH+TA)+TA+CL
(TH+2TA)+TA		(TH+2TA)+TA+CL
TH+(N-1)TA		TH+(N-1)TA+CL

TH : Text home address

TA : Text area number(Columns)

CL : Column are fixed by hardware(pin-programmable).

(Example)

Text home address : 0000H  
 Text area : 0020H  
 MD2=H, MD3=H : 32 columns  
 DUAL=H, MDS=L, MD0=L, MD1=H : 4 lines

0000H	0001H		001EH	001FH
0020H	0021H		003EH	003FH
0040H	0041H		005EH	005FH
0060H	0061H		007EH	007FH

(2)Set Graphic Home address

The starting address of the external display RAM used for graphic display is defined by this command. The graphic home address indicates the leftmost and uppermost position.

The relationship between external display RAM address and display position

GH		GA+CL
GH+GA		GH+GA+CL
(GH+GA)+GA		(GH+GA)+GA+CL
(GH+2GA)+GA		(GH+2GA)+GA+CL
GH+(N-1)GA		GTH+(N-1)GA+CL

GH : Graphic home address

GA : Graphic area number(Columns)

CL : Column are fixed by hardware(pin-programmable).

(Example)

Graphic Mode address : 0000H  
 Graphic Area : 0020H  
 MD2=H, MD3=H : 32 columns  
 DUAL=H, MDS=L, MD0=H, MD1=H : 2 lines

0000H	0001H	.....	001EH	001FH
0020H	0021H	.....	003EH	003FH
0040H	0041H	.....	005EH	005FH
0060H	0061H	.....	007EH	007FH
0080H	0081H	.....	009EH	009FH
00A0H	00A1H	.....	00BEH	00BFH
00C0H	00C1H	.....	00DEH	00DFH
00E0H	00E1H	.....	00FEH	00FFH
0100H	0101H	.....	011EH	011FH
0120H	0121H	.....	013EH	013FH
0140H	0141H	.....	015EH	015FH
0160H	0161H	.....	017EH	017FH
0180H	0181H	.....	019EH	019FH
01A0H	01A1H	.....	01BEH	01BFH
01C0H	01C1H	.....	01DEH	01DFH
01E0H	01E1H	.....	01FEH	01FFH

(3)Set Text Area

The display columns are defined by the hardware setting. The command can be used to adjust the columns of the display.

(Example)

LCD Size : 20 columns, 4 lines  
 Text home address : 0000H  
 Text Area : 0014H  
 MD2=H, MD3=H : 32 columns  
 DUAL=H, MDS=L, MD0=L, MD1=H : 4 lines

0000	0001	.....	0013	0014	.....	001F
0014	0015	.....	0027	0028	.....	0033
0028	0029	.....	003B	003C	.....	0047
003C	003D	.....	004F	0050	.....	005B
LCD						

(4)Set Graphic Area

The display columns are defined by the hardware setting. The command can be used to adjust the columns of the graphic display.

(Example)

LCD Size : 20 columns, 2 lines  
 Graphic home address : 0000H  
 Graphic Area : 0014H  
 MD2=H, MD3=H : 32 columns  
 DUAL=H, MDS=L, MD0=H, MD1=H : 2 lines

0000	0001	.....	0013	0014	.....	001F
0014	0015	.....	0027	0028	.....	0033
0028	0029	.....	003B	003C	.....	0047
003C	003D	.....	004F	0050	.....	005B
0050	0051	.....	0063	0064	.....	006F
0064	0065	.....	0077	0078	.....	0083
0078	0079	.....	008B	008C	.....	0097
008C	008D	.....	009F	00A0	.....	00AB
00A0	00A1	.....	00B3	00B4	.....	00BF
00B4	00B5	.....	00C7	00C8	.....	00D3
00C8	00C9	.....	00DB	00DC	.....	00E7
00DC	00DD	.....	00EF	00F0	.....	00FB
00F0	00F1	.....	0103	0104	.....	011F
0104	0105	.....	0127	0128	.....	0123
0128	0129	.....	013B	013C	.....	0147
013C	013D	.....	014F	0150	.....	015B
LCD						

If the graphic area setting is set to match the desire number of columns on the LCD, the addressing scheme will be automatically modified so that the start address of each line equals the end address of the previous line + 1.

## Mode Set

Code	Function	Operand
1000x000	OR mode	-
1000x001	EXOR mode	-
1000x011	AND mode	-
1000x100	TEXT ATTRIBUTE mode	-
10000xxx	Internal character generator mode	-
10001xxx	External character generator mode	-

The display mode is defined by this command. The display mode does not change until the next command is sent. The logical OR, EXOR, AND of text or graphic display can be displayed. In internal character generator mode, character codes 80H to FFH are automatically assigned the build-in character generator ROM. The character codes 80H to FFH are automatically assigned to the external character generator RAM.

(Example)

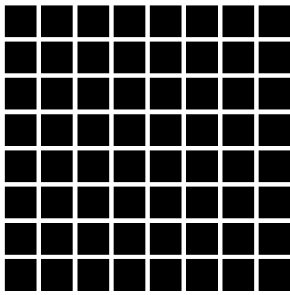

Graphic

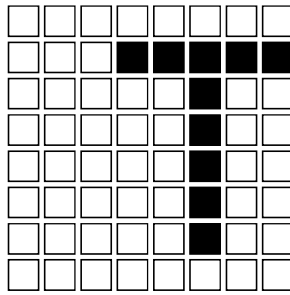

Text

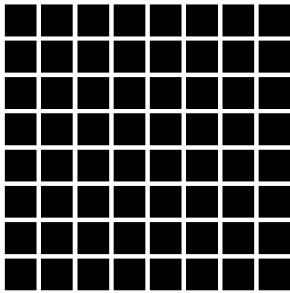

"OR"

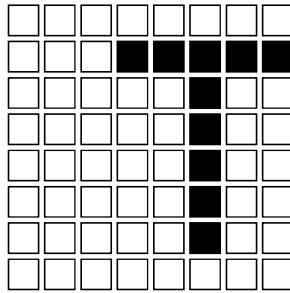

"AND"

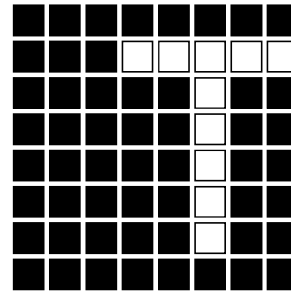

"EXOR"

(Note):

Attribute functions can only be applied to text display, since the attribute data is placed in the graphic RAM area.

### Attribute function

The attribute operations are Reverse display, Character blink and Inhibit. The attribute data is written into the graphic area, which was defined by the Set Control Word command. Only text display is possible in Attribute Function mode, graphic display is automatically disabled. However, the Display Mode command must be used to turn both Text and Graphic on in order for the Attribute function to be available.

The attribute data for each character in the text area is written into the same address in the graphic area. The Attribute function is defined as follows.

Attribute RAM 1 byte 

x	x	x	x	d3	d2	d1	d0
---	---	---	---	----	----	----	----

d3	d2	d1	d0	
0	0	0	0	Normal display
0	1	0	1	Reverse display
0	0	1	1	Inhibit display
1	0	0	0	Blink of normal display
				Blink of reverse display
				Blink of inhibit display

### Display Mode

Code	Function	Operand
1001000	Display Off	-
1001xx10	Cursor on, blink off	-
1001xx11	Cursor on, blink on	-
100101xx	Text on, graphic off	-
100110xx	Text off, graphic on	-
100111xx	Text on, graphic on	-

1	0	0	1	D3	D2	D1	D0
---	---	---	---	----	----	----	----

D3: Cursor blink      1: on,      0:off

D2: Cursor display    1: on,      0:off

D3: Text display      1: on,      0:off

D3: Graphic display   1: on,      0:off

(Note)

It is necessary to turn on "Text display" and "Graphic display" in the following cases.

- a) Combination of text/graphic display
- b) Attribute function

### Cursor pattern select

Code	Function	operand
10100000	1-line cursor	-
10100001	2-line cursor	-
10100010	3-line cursor	-
10100011	4-line cursor	-
10100100	5-line cursor	-
10100101	6-line cursor	-
10100110	7-line cursor	-
10100111	8-line cursor	-

When cursor display is on, this command selects the cursor pattern in the range 1-line to 8-line. The cursor address is defined by the Cursor Pointer Set command.

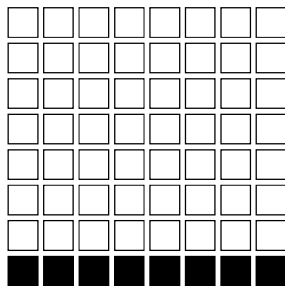

1-line cursor

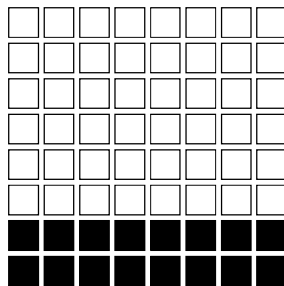

2-line cursor

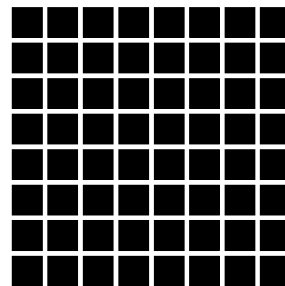

8-line cursor

### Data Auto Read/Write

Code	HEX.	Function	Operand
10110000	B0H	Set Data Auto Write	-
10110001	B1H	Set Data Auto Read	-
10110010	B2H	Auto Reset	-

This command is convenient for sending a full screen of data from the external display RAM. After setting auto mode, a Data Write (or Read) command must be sent between each datum. In Auto mode, the LCM cannot accept any other command.

The Auto Reset command must be sent to the LCM after all data has been sent, to clear Auto mode.

(Note)

a status check for Auto mode

(STA2, STA3 should be checked between sending of each datum. Auto Reset should be performed after checking STA3=1(STA2=1). Refer to the flowchart next page.

## Auto Read Mode

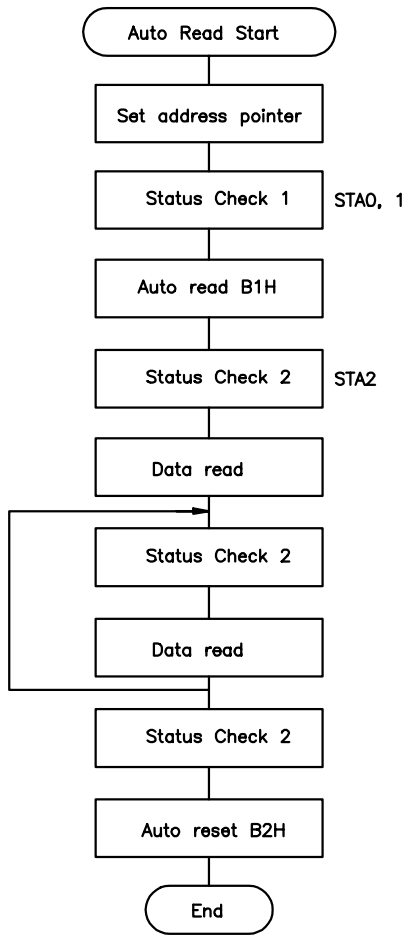

## Auto Write Mode

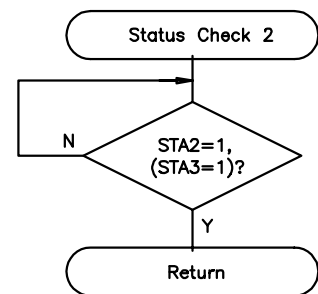
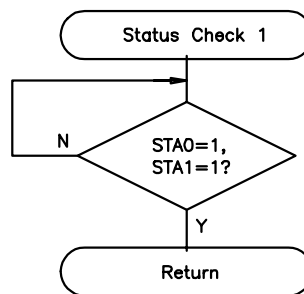
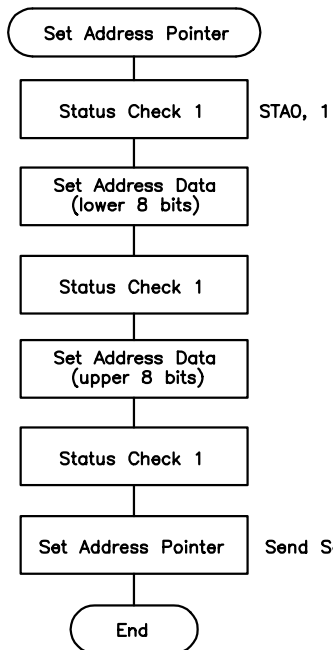
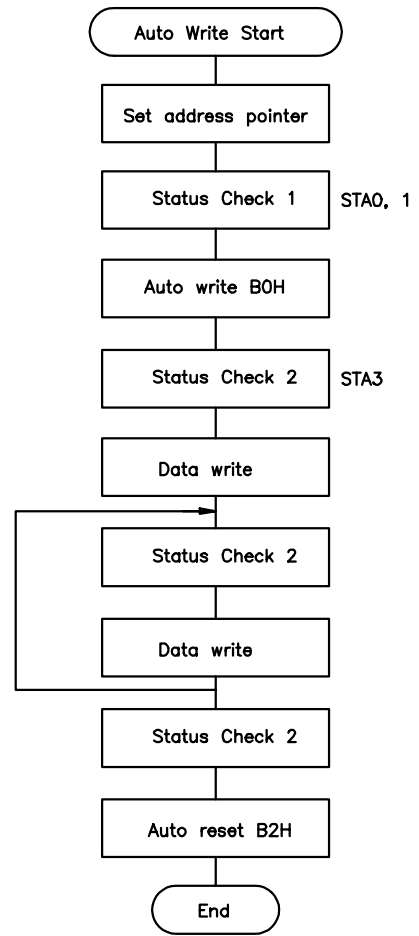

## Data Read/Write

Code	HEX.	Function	Operand
11000000	C0H	Data Write and increment ADP	Data
11000001	C1H	Data Read and increment ADP	-
11000010	C2H	Data Write and decrement ADP	Data
11000011	C3H	Data Read and decrement ADP	-
11000100	C4H	Data Write and Nonvariable ADP	Data
11000101	C5H	Data Read and Nonvariable ADP	-

This command is used for writing data from the MPU to external display RAM, and reading data from external display RAM to the MPU. Data Read should be executed after setting address using Set Address Pointer command. The address pointer can be automatically incremented or decremented using this command.

(Note)

This command is necessary for each 1-bit datum.  
Refer to the following flowchart:

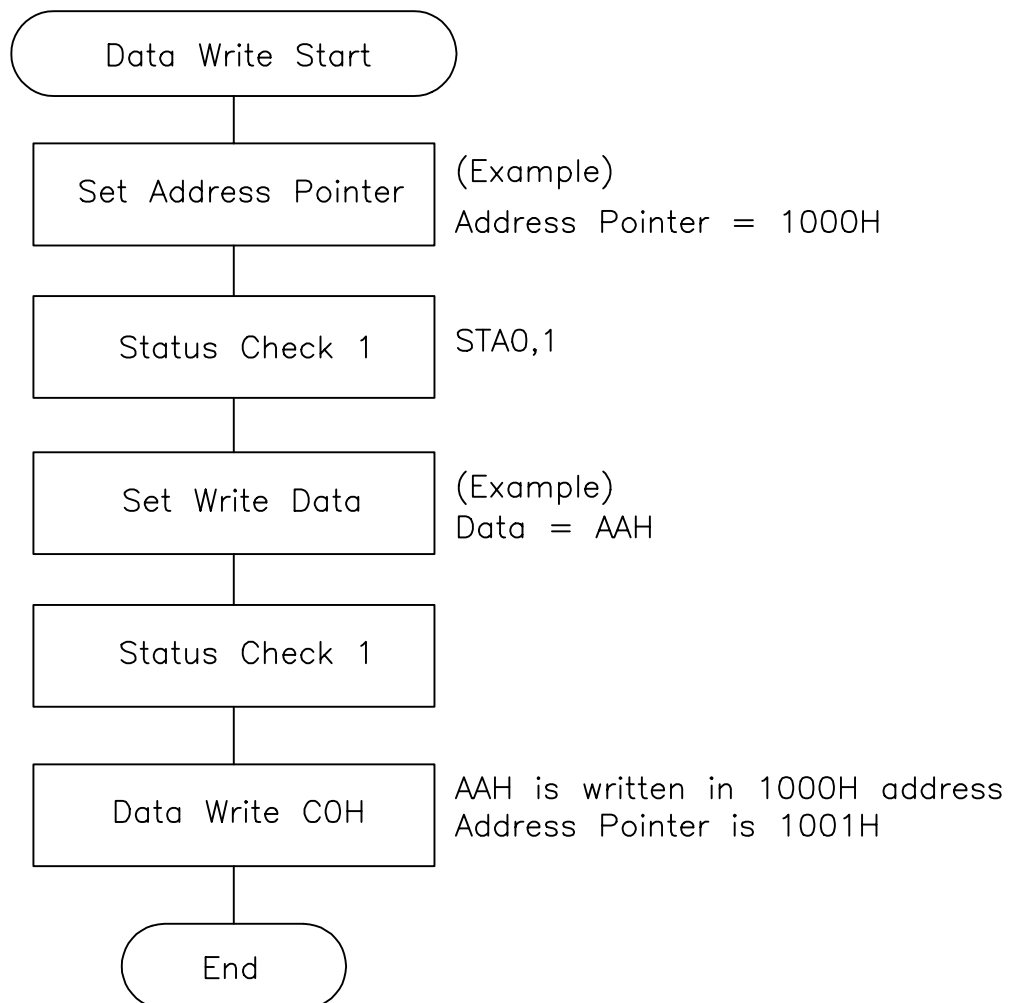

## Screen Peek

Code	HEX.	Function	Operand
11100000	E0H	Screen Peek	-

This command is used to transfer 1 byte of display data to the data stack; this byte can then be read from MPU by data access. The logical combination text and graphic display data on the LCD screen can be read by this command. The status (STA6) should be checked just after the Screen Peek command. If the address determined by the Set Address Pointer command is not in the graphic area, this command is ignored and a status (STA6) flag is set. Refer to the following flowchart:

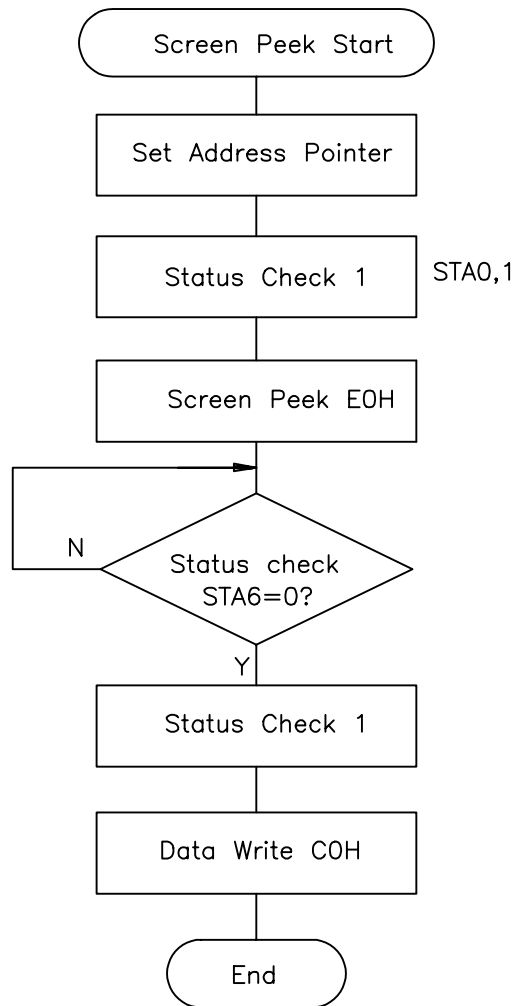

(Note)

This command is available when hardware column number and software column number are the same. Hardware column number is related to Set Text Area and Set Graphic Area command.

## Screen Copy

Code	HEX.	Function	Operand
11101000	E8H	Screen Copy	-

This command copies a single raster line of data to the graphic area.  
The start point must be using the Set Address Pointer command.

(Note 1)

If the attribute function is being used, this command is not available.  
(With attribute data is graphic area data)

(Note 2)

This command is not working for Dual-Scan because the controller IC T6963C cannot separate the upper screen data and lower screen.

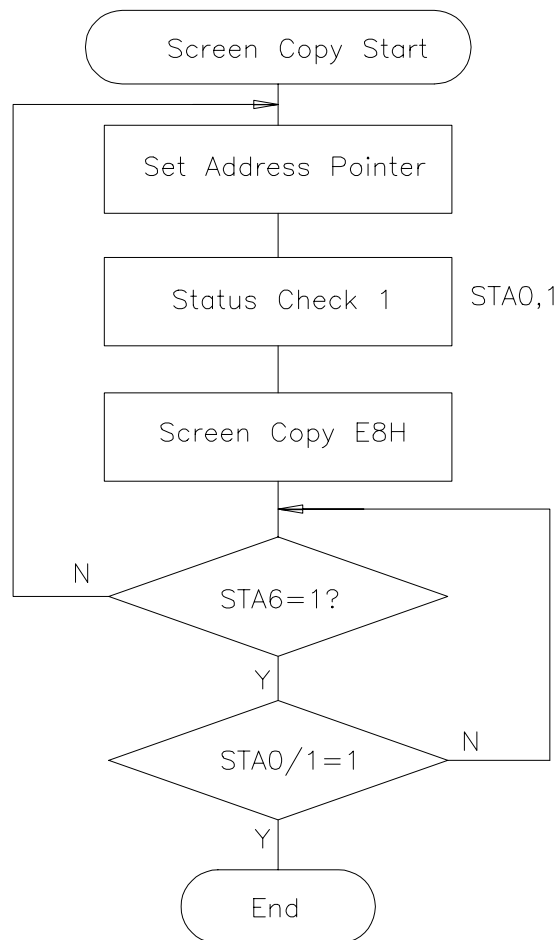

(Note)

This command is available when hardware column number and software column number are the same. Hardware column number is related to MD2 and MD3 setting. Software column number is related to Set Text Area and Set Graphic Area command.

## Bit Set/Reset

Code	Function	Operand
11110xxx	Bit Reset	-
11111xxx	Bit Set	-
1111x000	Bit 0 (LSB)	-
1111x001	Bit 1	-
1111x010	Bit 2	-
1111x011	Bit 3	-
1111x100	Bit 4	-
1111x101	Bit 5	-
1111x110	Bit 6	-
1111x111	Bit 7	-

This command use to set or reset a bit of byte specified by the address pointer. Only 1 bit can be set/reset at a time. Refer to the following flowchart:

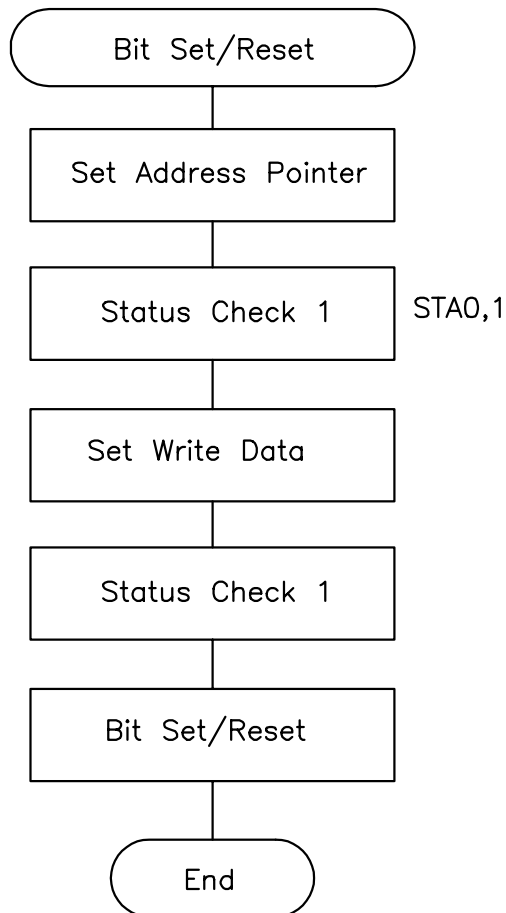

# CG-ROM CHARACTER CODE MAP

MSB \ LSB	0	1	2	3	4	5	6	7	8	9	A	B	C	D	E	F
0		!	"	#	\$	%	&	'	(	)	*	+	,	-	.	/
1	0	1	2	3	4	5	6	7	8	9	:	;	<	=	>	?
2	@	A	B	C	D	E	F	G	H	I	J	K	L	M	N	O
3	P	Q	R	S	T	U	V	W	X	Y	Z	[	\	]	^	_
4	'	a	b	c	d	e	f	g	h	i	j	k	l	m	n	o
5	P	q	r	s	t	u	v	w	x	y	z	{		}	~	
6	Ç	ü	é	â	ä	à	ç	ê	ë	è	ï	î	í	ä	å	
7	É	æ	Æ	ô	ö	ò	û	ü	ÿ	Ü	Ü	ƒ	£	¥	℞	ƒ

# DSIPLAY PATTERN

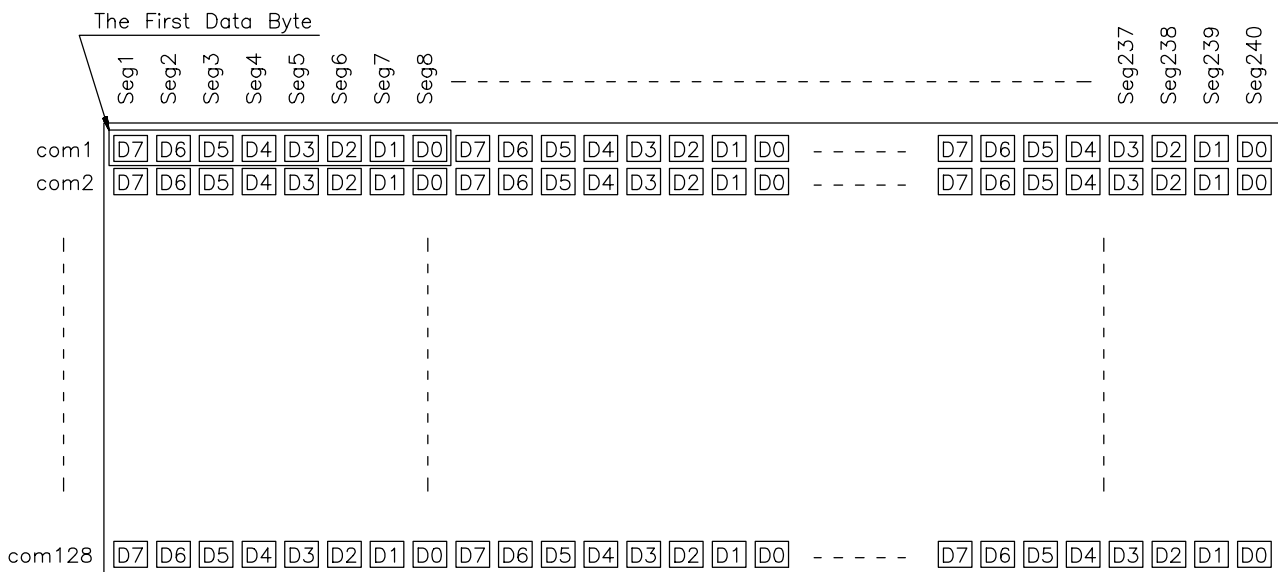

## RELIABILITY TEST

No	Item	Conditions		Note
1	High Temp. Operation	70°C	240 HR	
2	High Temp. Storage	80°C	240 HR	
3	Low Temp. Operation	-20°C	240 HR	
4	Low Temp. Storage	-30°C	240 HR	
5	High Temp./Humid Storage	60°C 90%RH	240 HR	
6	Thermal Shock	-20°C ,30min +60°C ,30min	10 cycles	
7	Vibration Test ( IEC-68-2-6 )	Frequency : 10~55 Hz Duration : 20 times, 6 min/time Amplitude : 0.75 mm	-	
8	Shock ( IEC 68-2-27)	Duration : 11 mS Acceleration : 100g	-	X, Y, Z direction

## APPEARANCE CHECK

CONDIITON OF APPEARANCE CHECK:

- (1) Specimen shall be checked by eyes in distance of 30cm under 40w-fluorescence lamp.
- (2) Checking direction shall be in 45 degree from perpendicular line op specimen surface.

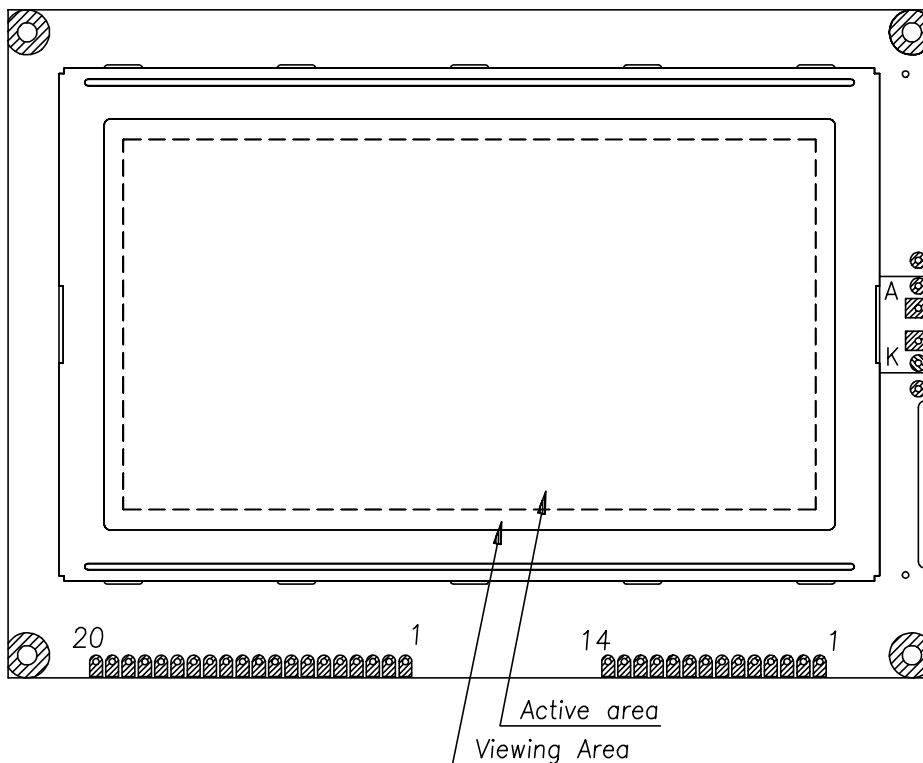

## HANDLING PRECAUTIONS

- (1) Treat polarizer very carefully since it is easy to be damaged.
- (2) When cleaning the display surface, use soft cloth (e.g. gauss) with a solvent (recommended below) and wipe lightly.

- ◆ ethyl alcohol
- ◆ iso-procolol

Do not wipe the display surface with dry or hard materials that will damage the polarizer surface.

Do not use the following solvents:

- ◆ water
- ◆ ketone
- ◆ aromatics

- (3) Direct current causes electro-chemical reaction with remarkable degradation of the display quality. Give careful consideration to prevent direct current at ON/OFF timing and during operation.
- (4) Avoid strong shock and drop from the height.
- (5) To prevent LCD panels from degradation, do not operate or store them exposed directly to sunshine or high temperature/humidity.
- (6) Give careful consideration to avoid electrical static discharge with causes uneven contrast.
- (7) Even a small condensation on the contact pads (terminals) causes electro-chemical reaction which makes missing row and column. Give careful attention to avoid condensation. When assembling with zebra connector, clean the surface of the pads with alcohol and keep the air very clean.



