



CONTENT

1. General description	3
2. Maximum absolute limit	3
3. Mechanical characteristics	3
a) Physical data	
b) External dimensions	
4. Electrical characteristics	4
a) DC characteristics	
b) AC characteristics	
c) EL backlight	
d) LED backlight	
5. Operating Principles	7
a) Pin description	
b) Block diagram	
c) Instruction description	
6. Operating Methods	13
a) Interface with MPU	
b) Power supply	
c) Operating example	



1. General description

SC204A, a dot-matrix character LCD module, design for displaying 4 line 20 row characters. Character font is 5X7 dots with cursor. The SC204A provides two types of interfaces to MPU: 4-bit and 8-bit interfaces. SC204A can includes EL or LED backlight for custom design. The custom can design for color of EL or LED backlight, viewing angle and LCD type.

2. Maximum absolute limit

Characteristics	Symbol	Ratings	Remark
Operating Voltage	VDD	-0.3V to +7.0V	
Driver Supply Voltage	VLCD	VDD - 12V to VDD + 0.3V	
Input Voltage Range	VIN	-0.3V to VDD + 0.3V	
Operating Temperature	TA1	0°C to+50°C	Normal temperature LCM
	TA2	-20°C to+60°C	Wide temperature LCM
Storage Temperature	TSTO	-25°C to+70°C	

Note: Stresses beyond those given in the Absolute Maximum Rating table may cause operational errors or damage to the device.

3. Mechanical characteristics

a) Physical data

ITEM	Standard value	Unit	Remark
Number of characters	20×4		
Module size	98.0×60.0×14.0	mm	
Viewing area	76.0×26.0	mm	
Active area	70.4×20.80	mm	
Character size	4.75×2.95	mm	
Character pith	5.35×3.55	mm	
Approx. weight		g	
Drive method	1/5bias 1/16 duty		

b) External dimensions

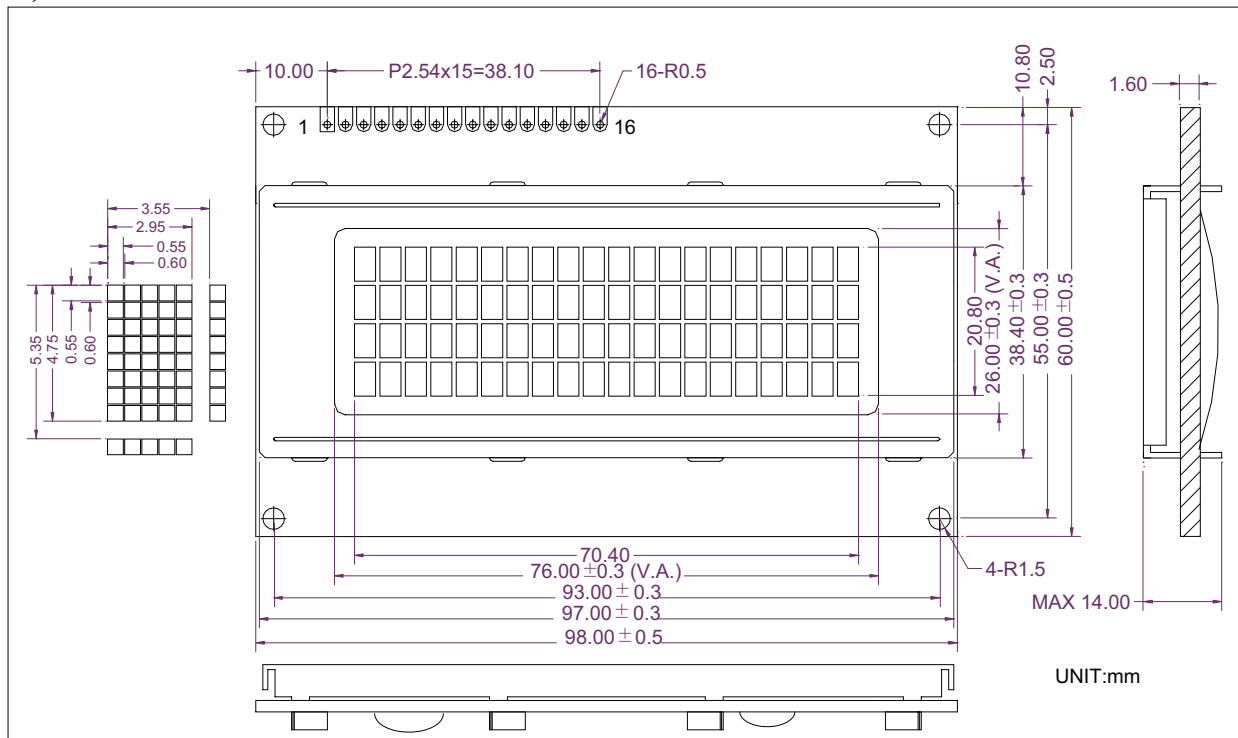



4. Electrical characteristics

a) DC CHARACTERISTICS (TA = 25°C, VDD = 4.5 to 5.5V)

Characteristics	Symbol	Limit			Unit	Test Condition
		Min.	Typ.	Max.		
Input High Voltage	V _{ih}	2.2		VDD	V	
Input Low Voltage	V _{il}	-0.3		0.6	V	
Input High Current	I _{ih}	-2.0		2.0	uA	VDD = 5.0V
Input Low Current	I _{il}	-20	-50	-100	uA	
Output High Voltage	V _{oh}	2.4	-	VDD	V	I _{OH} = - 0.1mA Pins: DB7-0
Output Low Voltage	V _{ol}	-	-	0.4	V	I _{OL} = 0.1mA Pins: DB7-0
LCD Voltage	V _{lcd}		5		V	
Operating Current	I _{dd}		1.0		mA	

Note: VDD = 5V

b) AC characteristics

b.1) AC CHARACTERISTICS (TA = 25°C, VDD = 4.5 to 4.5V)

Write Mode (Writing data from MPU to LCD module)

Characteristics	Symbol	Limit			Unit	Test Condition
		Min.	Typ.	Max.		
E Cycle Time	t _c	1000			ns	PinE
E Pulse Width	t _{pw}	450	-	-	ns	PinE
E Rise/Fall Time	t _{R,tF}	-	-	25	ns	PinE
Address Setup Time	t _{sp-i}	60			ns	Pins: RS, R/W, E
Address Hold Time	t _{HD1}	20			ns	Pins: RS, R/W, E
Data Setup Time	t _{sP2}	195			ns	Pins: DB7-0
Data Hold Time	t _{HD2}	10	-	-	ns	Pins: DB7-0

Read Mode (Reading data from LCD module to MPU)

Characteristics	Symbol	Limit			Unit	Test Condition
		Min.	Typ.	Max.		
E Cycle Time	t _c	1000			ns	PinE
E Pulse Width	t _w	450			ns	PinE
E Rise/Fall Time	t _{R,tF}			25	ns	PinE
Address Setup Time	t _{sp-i}	60			ns	Pins: RS, R/W,E
Address Hold Time	t _{HD1}	20			ns	Pins: RS, R/W,E
Data Output Delay Time	t _D			360	ns	Pins: DB7-0
Data hold time	t _{HD2}	5.0	-	-	ns	Pin DB7- 0



b.2) AC CHARACTERISTICS ($t_a = 25^\circ\text{C}$, $V_{DD} = 4.5$ to 5.5V)

Write Mode (Writing Data from MPU to LCD module)

Characteristics	Symbol	Limit			Unit	Test Condition
		Min.	Typ.	Max.		
E Cycle Time	tc	400			ns	PinE
E Pulse Width	tpw	150	-	-	ns	PinE
E Rise/Fall Time	tR,tF	-	-	25	ns	PinE
Address Setup Time	tsp-i	30			ns	Pins: RS, R/W, E
Address Hold Time	tHD1	10			ns	Pins: RS, R/W, E
Data Setup Time	tsP2	40			ns	Pins: DB7-0
Data Hold Time	tHD2	10	-	-	ns	Pins: DB7-0

Read Mode (Reading Data from LCD module to MPU)

Characteristics	Symbol	Limit			Unit	Test Condition
		Min.	Typ.	Max.		
E Cycle Time	tc	400			ns	Pin E
E Pulse Width	tw	150			ns	Pin E
E Rise/Fall Time	tR,tF			25	ns	Pin E
Address Setup Time	tsp-i	30			ns	Pins: RS, R/W,E
Address Hold Time	tHD1	10			ns	Pins: RS, R/W,E
Data Output Delay Time	tD			100	ns	Pins: DB7-0
Data hold time	tHD2	20	-	-	ns	Pin DB7-0

c) EL backlight

EL ,Cold Cathode Fluorescent Lamp and LED etc, are available as backlight for LCD Module upon your choice ,your request.

1.EL

(1) Features

Max 1.3mm thickness (Max 1.5mm for lead portion).

Wide driving condition of 60-1000Hz and 150V AC Max .with inverter , step-up voltage from 1.5V battery is available.

Emitted colors are blue-green and white .

Operating characteristics

(2) Electrical Characteristics

Voltage vs. Brightness

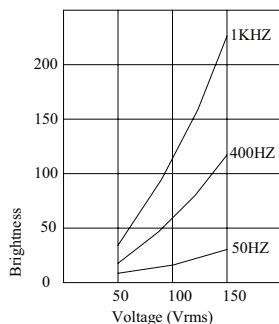

Voltage vs. Current Density

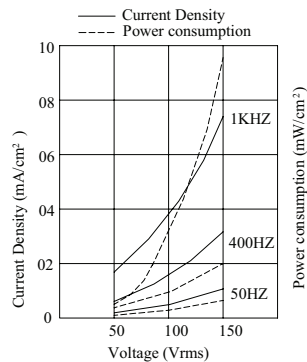

Life Characteristics

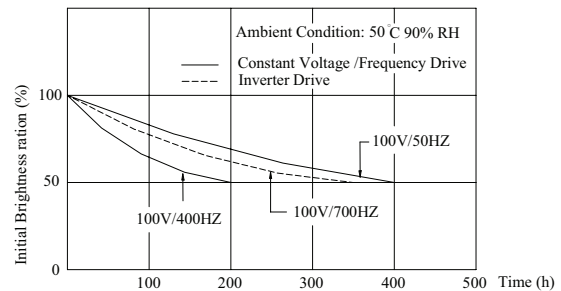

d) LED backlight

(1)Features

Low voltage driving (DC) is available without inverter.



Long life time 100000 hours (average).
 No noise occurrence.
 Various color of yellow-green and amber etc.
 Operating characteristics

(2)Electrical Characteristics (Reference Data)

Forward Current Derating Curve

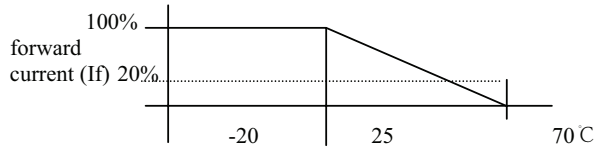

Note : The above spec . are only for reference

Wave Length vs. relative Light intensity

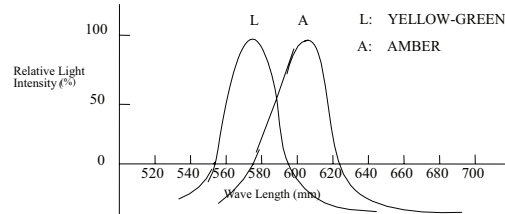

TIMING CHARACTERISTICS

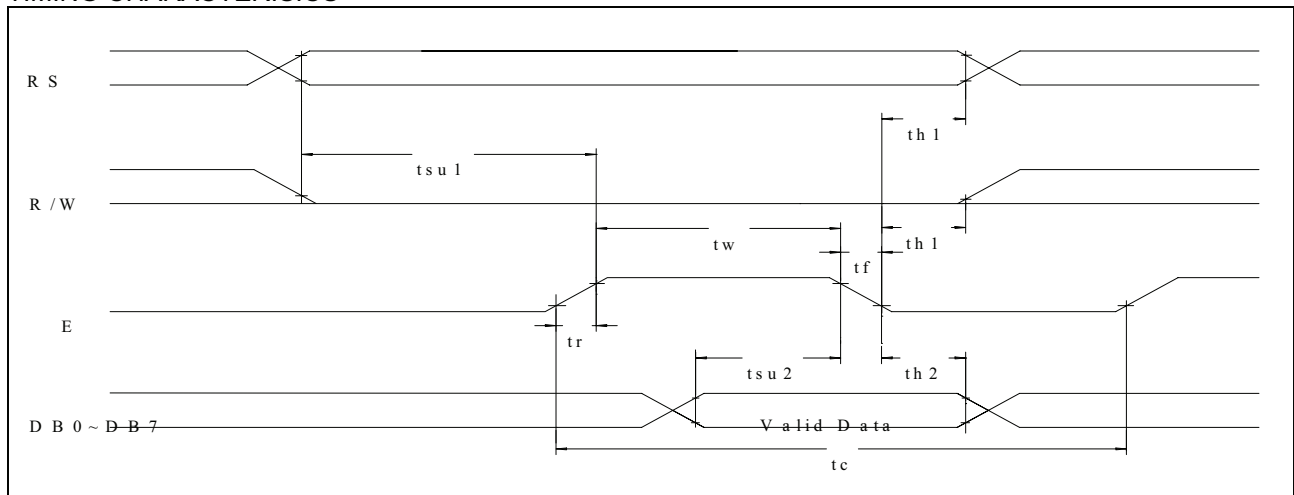

Write Timing

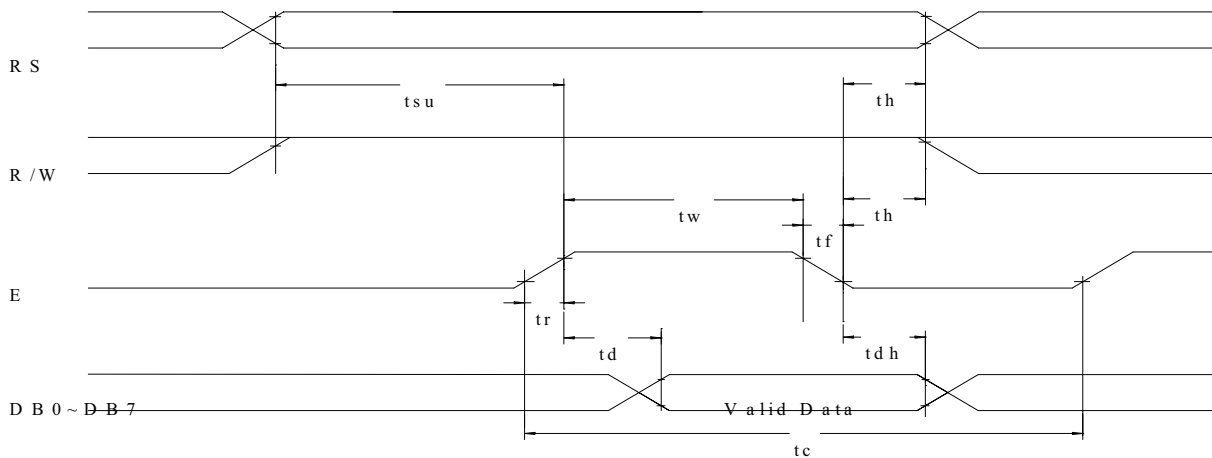

Read Timing



5. Operating Principles

a) Pin description

Pin NO.	Symbol	Level	Function
1	VSS	0V	Ground
2	VDD	4.5V~5.5V	Supply voltage for logic
3	V0		Variable voltage for LCD
4	RS	H/L	H: Instruction code L: Data
5	R/W	H/L	H: Read signal L: Write signal
6	E	H→L	enable signal
7	DB0	H/L	Data bits In case of 4 bits instruction, data is transferred by twice using only 4 buses of D4 – D7 ,and D0 – D3 are not used , first operation is higher order 4 bits and second is lower 4 bits of 8 bits , but in case of 8 bits instruction , data is transferred by data by data bus of D0 – D7
8	DB1	H/L	
9	DB2	H/L	
10	DB3	H/L	
11	DB4	H/L	
12	DB5	H/L	
13	DB6	H/L	
14	DB7	H/L	
15	BLA(+)	4.2V	Supply voltage for LED-Backlight
16	BLK(-)	0V	Supply voltage for LED-Backlight

b) Block Diagram

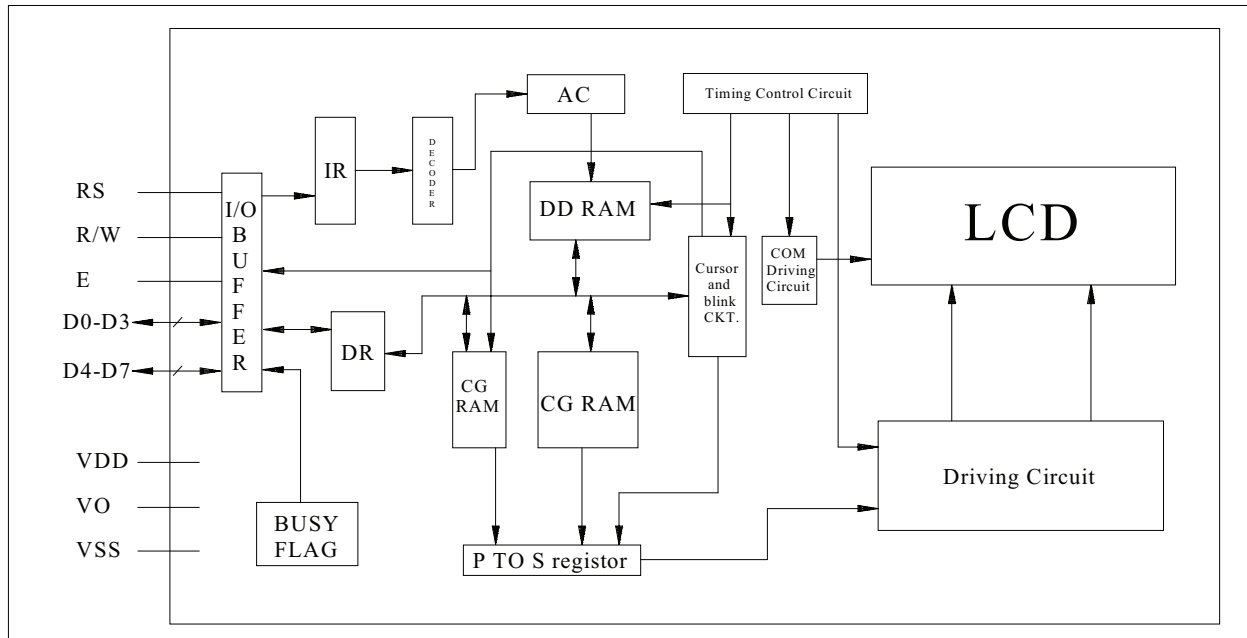

- Data Register (DR): This is a register used for temporary storage of the data read/write from/into DD RAM and CG RAM.
- Instruction Register (IR): This is a register available for storing the instruction codes and address information of display data (DD) RAM and character generator (CG) RAM.
- BUSY FLAG (BF): When the Busy Flag is "1", it shows that LCM is in internal operation and it cannot accept the next instruction.
- Character Generator (CG) ROM: This ROM generates character patterns from 8-bit character code and provides 192 character patterns.
- Character Generator (CG)RAM: This RAM allows the user to rewrite the character patterns freely according to the program.
- Address Counter (AC): This address counter is used to give the address information of DD RAM and CG RAM.



- g. Display Data (DD) RAM: This display data RAM is used to store the display data expressed by 8-bit character code . The capacity is 80x 8bits and data for 80 characters can be storage.
- h. Cursor and Blink Control Circuit: This circuit generates the cursor and blink.

RAM's address and the LCD's position shown bellows.

Display Character address code:

Display position	1	2	3	4	5	6	7	8	9	10	11	12	13	14	15	16
DDRAM Address	00	01	02	03	04	05	06	07	08	09	0A	0B	0C	0D	0E	0F
	40	41	42	43	44	45	46	47	48	49	4A	4B	4C	4D	4E	4F

Relationship between Character Code (DDRAM) and character Pattern (CGRAM)

Character code DD RAM Data								CG RAM Address						Character Pattern CG RAM Data							
B7	B6	B5	B4	B3	B2	B1	B0	B5	B4	B3	B2	B1	B0	B7	B6	B5	B4	B3	B2	B1	B0
0	0	0	0	x	0	0	0	0	0	0	0	0	0	x	x	x	1	1	1	1	1
											0	0	1				0	0	0		
											0	1	0				0	0	0		
											0	1	1				0	0	0		
											1	0	0				0	0	0		
											1	0	1				0	0	0		
											1	1	0				0	0	0		
											1	1	1				0	0	0		
0	0	0	0	x	0	0	1	0	0	1	0	0	0	x	x	x	0	1	1	1	0
											0	0	1				0	0	0		
											0	1	0				0	0	0		
											0	1	1				0	0	0		
											1	0	0				0	0	0		
											1	0	1				0	0	0		
											1	1	0				0	0	0		
											1	1	1				0	0	0		

1. ■ It means that the bit0~2 of the character code correspond to the bit3~5 of the CG RAM address.
2. ■ these areas are not used for display, but can be used for the general data RAM.
3. When all of the bit4-7 of the character code is 0, CG RAM character patterns are selected.
4. " 1 ": Selected," 0 ": No selected," X": Do not care (0 or 1).
5. for example (1), to set character code (b2 = b1 = b0 = 0, b3 = 0 or 1, b7-b4 = 0) is to display" T". That means character code (00)16, and (08)16 can display" T" character.
6. The bits 0-2 of the character code RAM is character pattern line position. The 8th line is the cursor position and display is formed by logical OR with the cursor



CGROM Character Code Table:

Upper 4bit / Lower 4bit	LLLL	LLLH	LLHL	LLHH	LHLL	LHLH	LHHL	LHHH	HLLL	HLLH	HLHL	HLHH	HHLL	HHLH	HHHL	HHHH
LLLL	CG RAM (1)															
LLLH	(2)															
LLHL	(3)															
LLHH	(4)															
LHLL	(5)															
LHLH	(6)															
LHHL	(7)															
LHHH	(8)															
HLLL	(1)															
HLLH	(2)															
HLHL	(3)															
HLHH	(4)															
HHLL	(5)															
HHLH	(6)															
HHHL	(7)															
HHHH	(8)															



c) Instruction description

Control and display instructions will show in details as following:

c.1) Clear Display

RS	R/W	D7	D6	D5	D4	D3	D2	D1	D0
0	0	0	0	0	0	0	0	0	1

It clears the whole display and sets display data RAM's address 0 in address counter.

c.2) Return Home

RS	R/W	D7	D6	D5	D4	D3	D2	D1	D0
0	0	0	0	0	0	0	0	1	X

X: Do not care (0 or 1)

It sets display data RAM's address 0 in address counter and display returns to its original position. The cursor or blink goes to the left edge of the display (to the 1st line if 2 lines are displayed). The contents of the Display Data RAM do not change.

c.3) Entry Mode Set

During writing and reading data, it sets cursor move direction and shifts the display.

RS	R/W	D7	D6	D5	D4	D3	D2	D1	D0
0	0	0	0	0	0	0	1	I/D	S

I / D = 1: Increment, I / D = 0: Decrement.

S = 1: The display shift, S = 0: The display does not shift

S= 1	I/D= 1	It shifts the display to the left
S= 1	I/D=0	It shifts the display to the right

c.4) Display On/Off Control

RS	R/W	D7	D6	D5	D4	D3	D2	D1	D0
0	0	0	0	0	0	1	D	C	B

D = 1: Display on, D = 0: Display off

C = 1: Cursor on , C = 0: Cursor off

B = 1: Blinks on, B= 0: Blinks off

c.5) Cursor or Display Shift

Without changing DD RAM's datas, it can move cursor and shift display

RS	R/W	D7	D6	D5	D4	D3	D2	D1	D0
0	0	0	0	0	1	S/C	R/L	X	X

S/C	R/L	Description	Address Counter
0	0	Shift cursor to the left	AC = AC - 1
0	1	Shift cursor to the right	AC = AC + 1
1	0	Shift display to the left. Cursor follows the display shift	AC=AC
1	1	Shift display to the right. Cursor follows the display shift	AC=AC

c.6) Function Set

RS	R/W	D7	D6	D5	D4	D3	D2	D1	D0
0	0	0	0	1	DL	N	F	X	X

X: Do not care (0 or 1)

DL: It sets interface data length.

DL = 1: Datas are transferred with 8-bit lengths (DB7 - 0).DL = 0: Datas are transferred with 4-bit lengths (DB7 - 4).

(It needs two times to transfer datas) N: It sets the number of the display line. N = 0: One-line display. N = 1: Two-line display. F: It sets the character font. F = 0: 5 x 7 dots character font.

F = 1: 5 x 10 dots character font.

N	F	No. of Display Lines	Character Font	Duty Factor
0	0	1	5X7 dots	1 / 8
0	1	1	5x 10 dots	1 / 11
1	X	2	5x7 dots	1 / 16



c.7) Set Character Generator RAM Address

RS	R/W	D7	D6	D5	D4	D3	D2	D1	D0
0	0	0	1	a	a	a	a	a	a

It sets character generator RAM address (aaaaaa)2 to the address counter. Character generator RAM data can read or write after this setting.

c.8) Set Display Data RAM Address

RS	R/W	D7	D6	D5	D4	D3	D2	D1	D0
0	0	1	a	a	a	a	a	a	a

It sets display data RAM address (aaaaaa)2 to the address counter.

Display data RAM can read or write after this setting.

In one-line display (N = 0), (aaaaaa)2; (00)16 - (4F)16

In two-line display (N = 1), (aaaaaa)2: (00)16 - (27)16,gfor the first line,

(aaaaaa)2: (40)16 - (67)16,gfor the second line.

c.9) Read Busy Flag and Address

RS	R/W	D7	D6	D5	D4	D3	D2	D1	D0
0	1	BF	a	a	a	a	a	a	a

When (BF = 1) indicates that the system is busy now, it will not accept any instruction until no busy (BF = 0). At the same time, the address counter content's (aaaaaa)2; is read out.

c.10) Write Data to Character Generator RAM or Display Data RAM

RS	R/W	D7	D6	D5	D4	D3	D2	D1	D0
1	0	d	d	d	d	d	d	d	d

It writes data (ddddddd)2 to character generator RAM or display data RAM.

c.11) Read Data from Character Generator RAM or Display Data RAM

RS	R/W	D7	D6	D5	D4	D3	D2	D1	D0
1	1	d	d	d	d	d	d	d	d

It reads data (ddddddd)2 from character generator RAM or display data RAM. To get the correct data readout is shown below:

(i)Set the address of the character generator RAM or display data RAM or shift the cursor instruction.

(ii) Send the "Read "instruction.



Instruction table

Instruction	Instruction Code										Description	Execution time (fosc=270KHz)
	RS	RW	D7	D6	D5	D4	D3	D2	D1	D0		
Clear Display	0	0	0	0	0	0	0	0	0	1	Write "20H" to DDRAM and set DDRAM address to "OOH" from AC	1.52ms
Return Home	0	0	0	0	0	0	0	0	1	-	Set DDRAM address to "OOH" from AC and return cursor to its original position if shifted. The contents of DDRAM are not changed.	1.52ms
Entry Mode Set	0	0	0	0	0	0	0	1	I/D	S	Assign cursor moving direction and enable the shift of entire display	38us
Display ON/OFF	0	0	0	0	0	0	1	D	C	B	Set display(D), cursor(C), and blinking of cursor(B) on/off control bit.	38us
Cursor or Display Shift	0	0	0	0	0	1	S/C	R/L	-	-	Set cursor moving and display shift control bit, and the direction, without changing of DDRAM data.	38us
Function Set	0	0	0	0	1	DL	N	F	-	-	Set interface data length (DL: 8-bit/4-bit), numbers of display line (N: 2-line/1-line) and, display font type (F:5x10dots/5x8dots)	38us
Set CGRAM Address	0	0	0	1	AC5	AC4	AC3	AC2	AC1	ACO	Set CGRAM address in address counter.	38us
Set DDRAM Address	0	0	1	AC6	AC5	AC4	AC3	AC2	AC1	ACO	Set DDRAM address in counter	38us
Read Busy Flag and Address Counter	0	1	BF	AC6	AC5	AC4	AC3	AC2	AC1	ACO	Whether during internal operation or not can be known by reading BF. The contents of address counter can also be read.	38us
Write Data to RAM	1	0	D7	D6	D5	D4	D3	D2	D1	DO	Write data into internal RAM (DDRAM/CGRAM).	38us
Read Data from RAM	1	1	D7	D6	D5	D4	D3	D2	D1	DO	Read data from internal RAM (DDRAM/CGRAM).	38us



6. Operating Methods

a) Interface with MPU

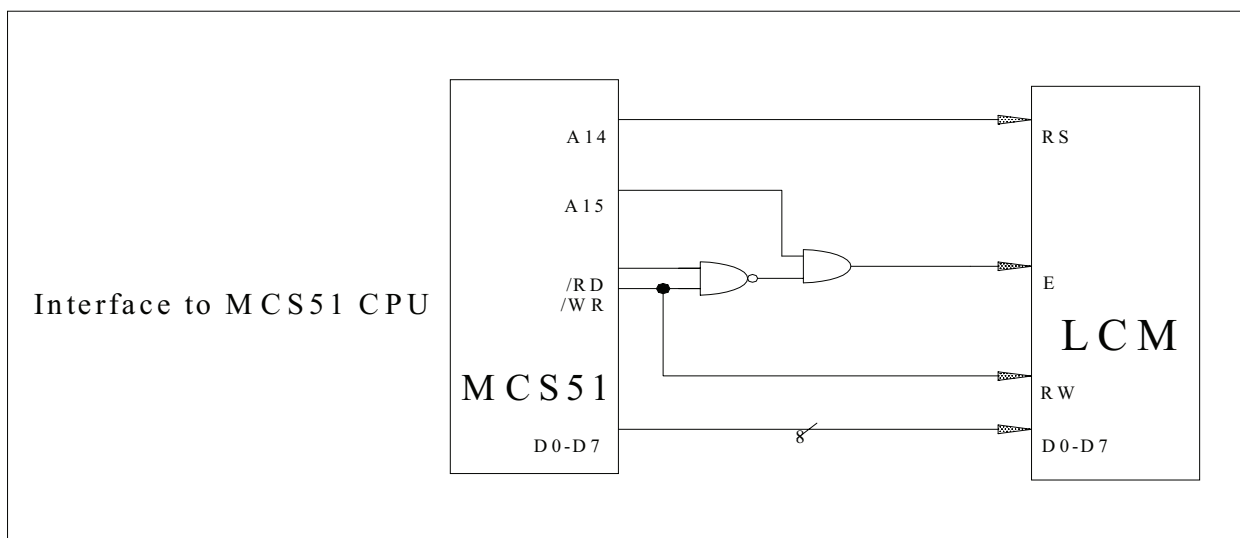
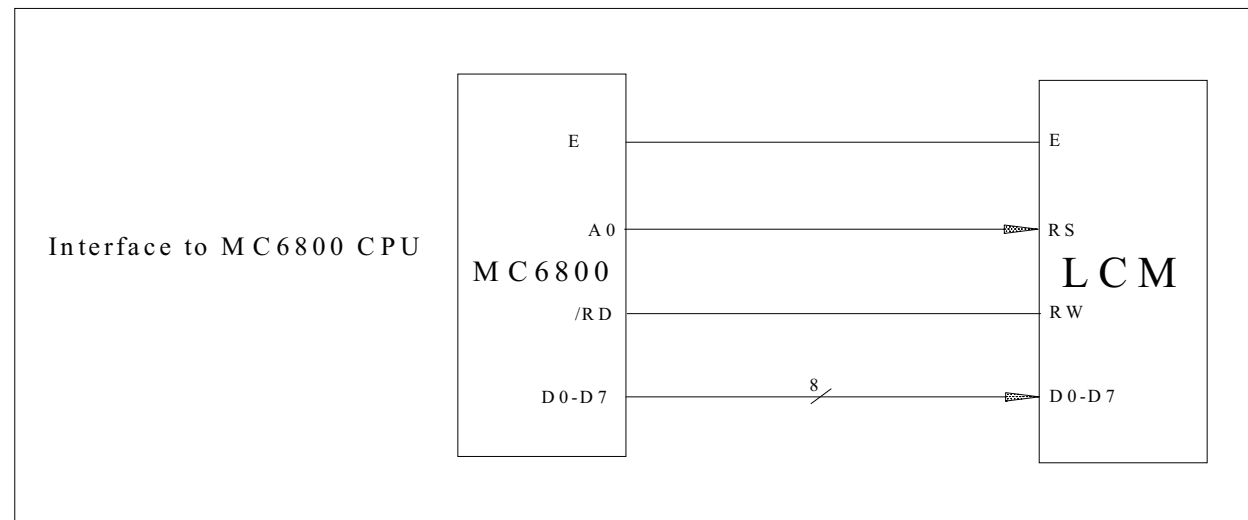
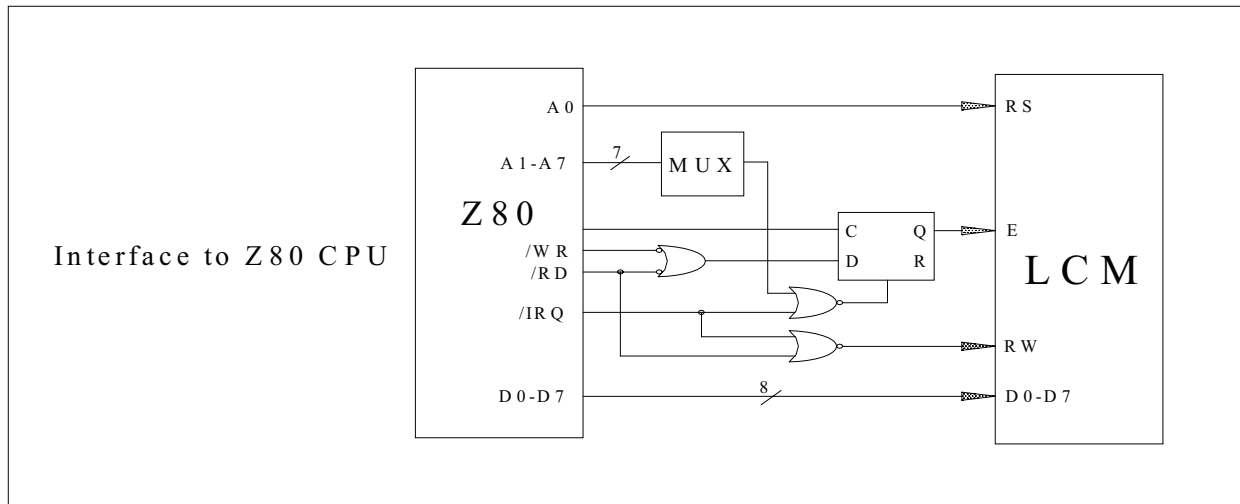



b) Power supply

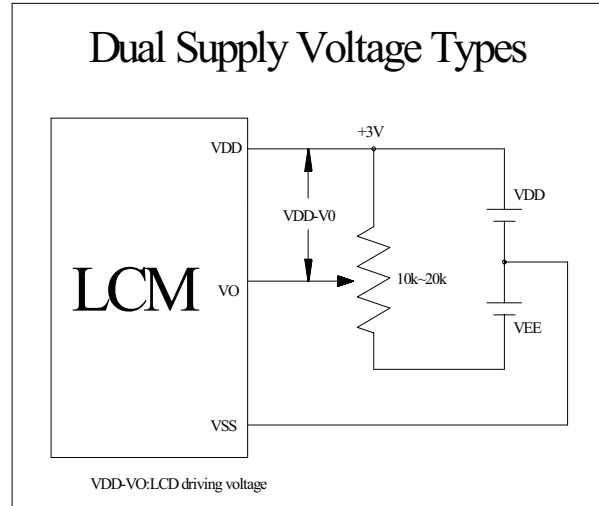
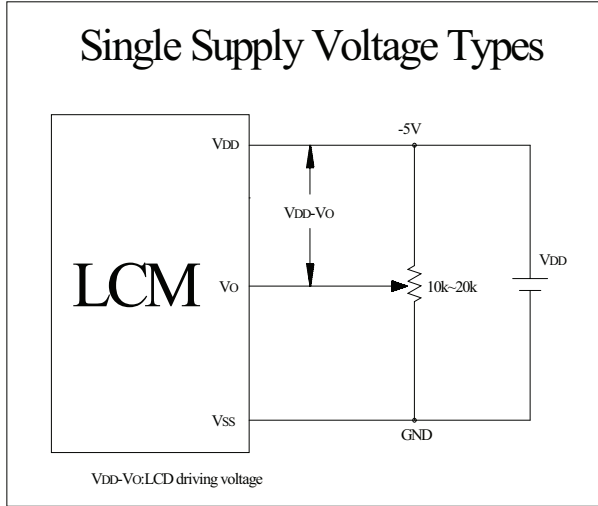

c) Operating example

8-Bit operation and 8-digit 1-line display (using internal reset)

No	Instruction	Display	Operation
1	Power on . (SPLC780A1 starts initializing)		Power on reset. No display.
2	Function set RS R/W D7 D6 D5 D4 D3 D2 D1 D0 0 0 0 0 1 1 0 0 X X		Set to 8-bit operation and select 1-line display line and character font.
3	Display on / off control 0 0 0 0 0 0 1 1 1 0	-	Display on. Cursor appears.
4	Entry mode set 0 0 0 0 0 0 0 1 1 0	-	Increase address by one. It will shift the cursor to the right when writing to the DD RAM / CG RAM. Now the display has no shift.
5	Write data to CG RAM / DD RAM 1 0 0 1 0 1 0 1 1 1	W_	Write "W". The cursor is incremented by one and shifted to the right.
6	Write data to CG RAM / DD RAM 1 0 0 1 0 0 0 1 0 1	WE_	Write "E ". The cursor is incremented by one and shifted to the right.
7	
8	Write data to CG RAM / DD RAM 1 0 0 1 0 0 0 1 0 1	WELCOME_	Write "E ". The cursor is incremented by one and shifted to the right.
9	Entry mode set 0 0 0 0 0 0 0 1 1 1	WELCOME_	Set mode for display shift when writing
10	Write data to CG RAM / DD RAM 1 0 0 0 1 0 0 0 0 0	ELCOME_	Write" "(space). The cursor is incremented by one and shifted to the right.



11	Write data to CG RAM / DD RAM 1 0 0 1 0 0 0 0 1 1	LCOME C	Write "C ". The cursor incremented by one and shifted the right.
12	
13	Write data to CG RAM / DD RAM 1 0 0 1 0 1 1 0 0 1	COMPAMY	Write "Y ". The cursor is incremented by one and shifted to the right.
14	Cursor Or Display Shift 0 0 0 0 0 1 0 0 X X	COMPAMY	Only shift the cursor's position to the left (Y).
15	cursor or display shift 0 0 0 0 0 1 0 0 X X	COMPAMY	Only shift the cursor's position to the left (M).
16	Write data to CG RAM / DD RAM 1 0 0 1 0 0 1 1 1 0	OMPANY	Write "N ". The display moves to the left.
17	cursor or display shift 0 0 0 0 0 1 1 1 X X	COMPANY	Shift the display and the cursor's position to the right.
18	cursor or display shift 0 0 0 0 0 1 0 1 X X	COMPANY	Shift the display and the cursor's position to the right.
19	Write data to CG RAM / DD RAM 1 0 0 1 0 0 0 0 0 0	OMPANY	Write " " (space). The cursor is incremented by one and shifted to the right
20	
21	return home 0 0 0 0 0 0 0 0 1 0	WELCOME	Both the display and the cursor return to the original position (address 0).

4-Bit operation and 8-digit 1-line display (using internal reset)

No	Instruction	Display	Operation
1	Power on . (SPLC780A1 starts initializing)		Power on reset. No display.
2	Function set RS R/W D7 D6 D5 D4 0 0 0 0 1 0		Set to 4-bit operation
3	Function set 0 0 0 0 1 0 0 0 0 0 X X		Set to 4-bit operation and select 1-line display line and character font.
4	Display on / off control 0 0 0 0 0 0 0 1 1 1 0 0	-	Display on. Cursor appears.
5	Entry mode set 0 0 0 0 0 0 0 0 1 1 0 0	-	Increase address by one. It will shift the cursor to the right when writing to the DD RAM / CG RAM. Now the display has no shift.
6	Write data to CG RAM / DD RAM 1 0 0 1 0 1 1 0 0 1 1 1	W_	Write "W ". The cursor is incremented by one and shifted to the right.



Reset function

At power on, it starts the internal auto-reset circuit and executes the initial instructions .
There are the initial procedures shown as follows:

